



PLAN 3  
SPANISH

PLAN 2  
TUSCAN

PLAN 1  
SPANISH

PLAN 4  
FRENCH COUNTRY



PLAN 3  
SPANISH

PLAN 3  
FRENCH COUNTRY

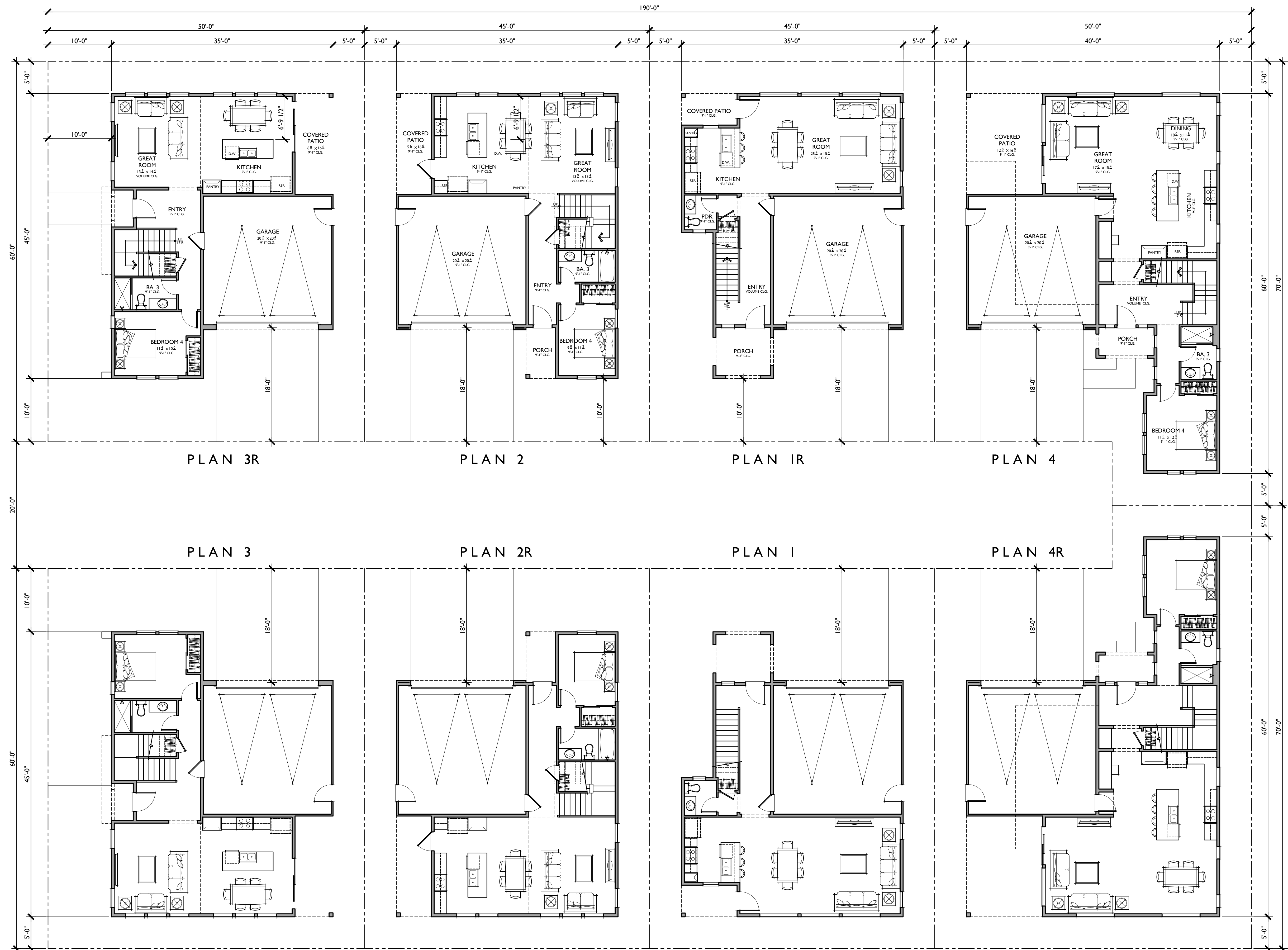

**PLAN 3**  
4 BEDROOMS / 3 BATHS  
2 - CAR GARAGE

FLOOR AREA TABLE	
1ST FLOOR	869 SQ. FT.
2ND FLOOR	996 SQ. FT.
<b>TOTAL LIVING</b>	<b>1865 SQ. FT.</b>
2 - CAR GARAGE	427 SQ. FT.
COVERED PATIO	95 SQ. FT.
PORCH	20 SQ. FT.

NOTE: SQUARE FOOTAGE MAY VARY DUE TO METHOD OF CALCULATION.

**PLAN 2**  
4 BEDROOMS / 3 BATHS  
2 - CAR GARAGE

FLOOR AREA TABLE	
1ST FLOOR	860 SQ. FT.
2ND FLOOR	975 SQ. FT.
<b>TOTAL LIVING</b>	<b>1835 SQ. FT.</b>
2 - CAR GARAGE	427 SQ. FT.
COVERED PATIO	88 SQ. FT.
PORCH	39 SQ. FT.

NOTE: SQUARE FOOTAGE MAY VARY DUE TO METHOD OF CALCULATION.

**PLAN 1**  
3 BEDROOMS / 2.5 BATHS  
2 - CAR GARAGE

FLOOR AREA TABLE	
1ST FLOOR	751 SQ. FT.
2ND FLOOR	955 SQ. FT.
<b>TOTAL LIVING</b>	<b>1710 SQ. FT.</b>
2 - CAR GARAGE	425 SQ. FT.
COVERED PATIO	44 SQ. FT.
PORCH	76 SQ. FT.

NOTE: SQUARE FOOTAGE MAY VARY DUE TO METHOD OF CALCULATION.

**PLAN 4**  
4 BEDROOMS / 3 BATHS  
2 - CAR GARAGE

FLOOR AREA TABLE	
1ST FLOOR	1,119 SQ. FT.
2ND FLOOR	1,054 SQ. FT.
<b>TOTAL LIVING</b>	<b>2173 SQ. FT.</b>
2 - CAR GARAGE	429 SQ. FT.
COVERED PATIO	191 SQ. FT.
PORCH	44 SQ. FT.

NOTE: SQUARE FOOTAGE MAY VARY DUE TO METHOD OF CALCULATION.

# CONCEPTUAL COMPOSITE FLOOR PLAN

First Floor

## LEUNG PROPERTY - PRODUCT 3

Antioch, Ca

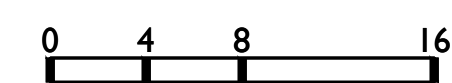

799.24099



PLAN 3R

PLAN 2

PLAN 1R

PLAN 4

PLAN 3

PLAN 2R

PLAN 1

PLAN 4R

PLAN 3  
4 BEDROOMS / 3 BATHS  
2 - CAR GARAGE

FLOOR AREA TABLE	
1ST FLOOR	869 SQ. FT.
2ND FLOOR	996 SQ. FT.
<b>TOTAL LIVING</b>	<b>1865 SQ. FT.</b>
2 - CAR GARAGE	427 SQ. FT.
COVERED PATIO	95 SQ. FT.
PORCH	20 SQ. FT.

NOTE: SQUARE FOOTAGE MAY VARY DUE TO METHOD OF CALCULATION.

PLAN 2  
4 BEDROOMS / 3 BATHS  
2 - CAR GARAGE

FLOOR AREA TABLE	
1ST FLOOR	860 SQ. FT.
2ND FLOOR	975 SQ. FT.
<b>TOTAL LIVING</b>	<b>1835 SQ. FT.</b>
2 - CAR GARAGE	427 SQ. FT.
COVERED PATIO	88 SQ. FT.
PORCH	37 SQ. FT.

NOTE: SQUARE FOOTAGE MAY VARY DUE TO METHOD OF CALCULATION.

PLAN 1  
3 BEDROOMS / 2.5 BATHS  
2 - CAR GARAGE

FLOOR AREA TABLE	
1ST FLOOR	751 SQ. FT.
2ND FLOOR	955 SQ. FT.
<b>TOTAL LIVING</b>	<b>1710 SQ. FT.</b>
2 - CAR GARAGE	425 SQ. FT.
COVERED PATIO	44 SQ. FT.
PORCH	76 SQ. FT.

NOTE: SQUARE FOOTAGE MAY VARY DUE TO METHOD OF CALCULATION.

PLAN 4  
4 BEDROOMS / 3 BATHS  
2 - CAR GARAGE

FLOOR AREA TABLE	
1ST FLOOR	1,119 SQ. FT.
2ND FLOOR	1,054 SQ. FT.
<b>TOTAL LIVING</b>	<b>2173 SQ. FT.</b>
2 - CAR GARAGE	429 SQ. FT.
COVERED PATIO	191 SQ. FT.
PORCH	44 SQ. FT.

NOTE: SQUARE FOOTAGE MAY VARY DUE TO METHOD OF CALCULATION.



SPANISH



FRENCH COUNTRY



TUSCAN

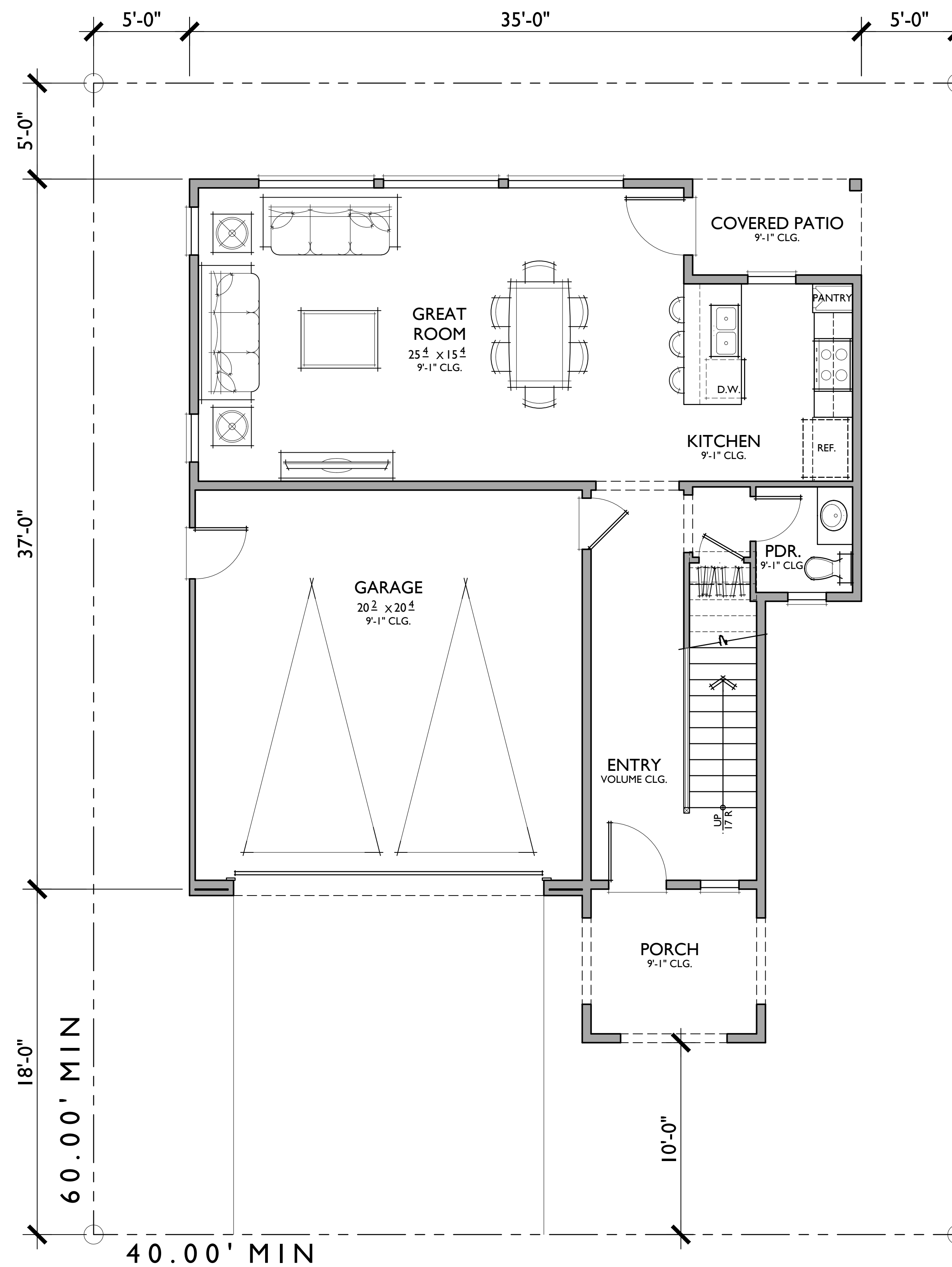
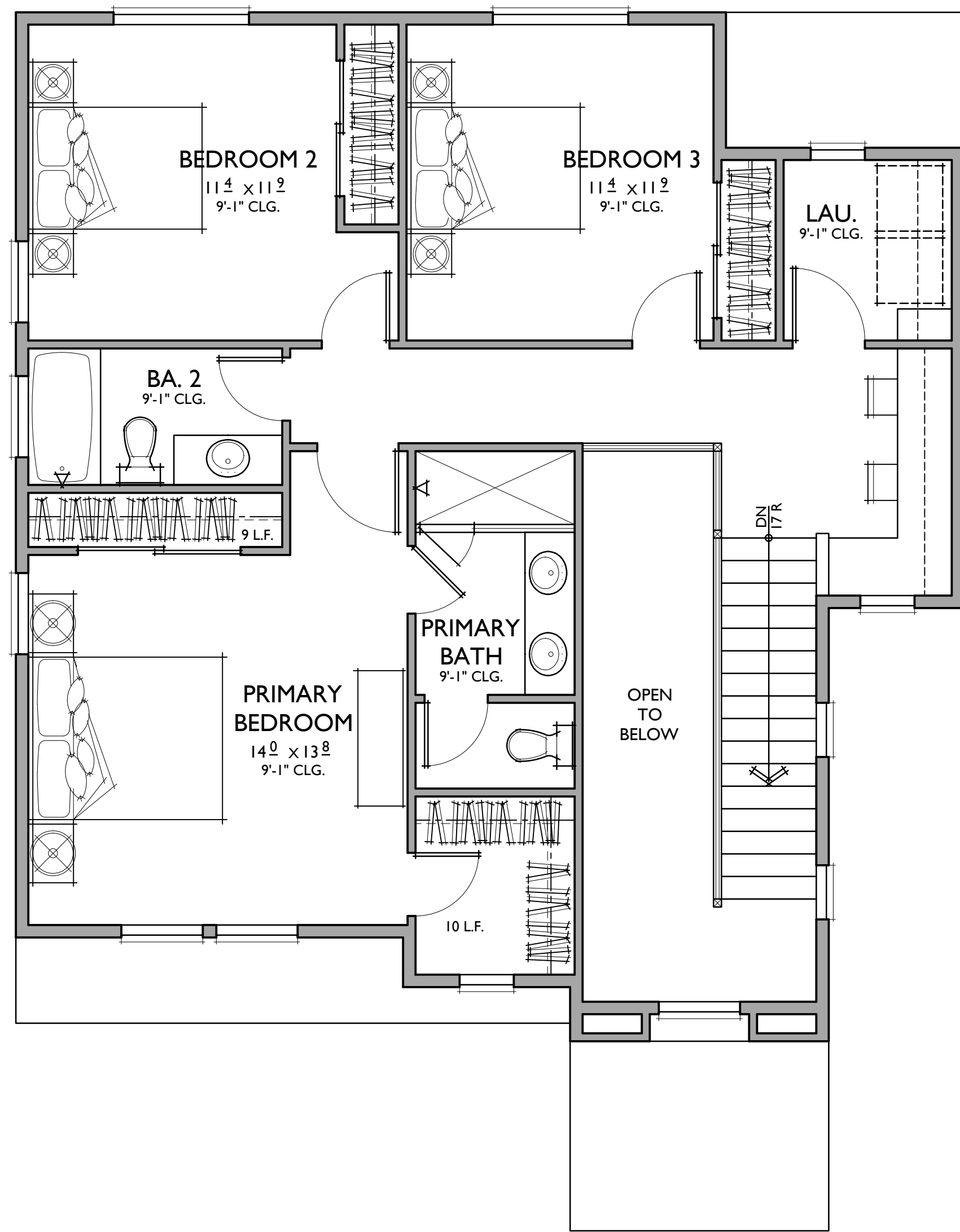

**PLAN I**

3 BEDROOMS / 2.5 BATHS  
2 - CAR GARAGE

FLOOR AREA TABLE	
1ST FLOOR	751 SQ. FT.
2ND FLOOR	955 SQ. FT.
<b>TOTAL LIVING</b>	<b>1710 SQ. FT.</b>
2 - CAR GARAGE	425 SQ. FT.
COVERED PATIO	44 SQ. FT.
PORCH	76 SQ. FT.

NOTE: SQUARE FOOTAGE MAY VARY DUE TO METHOD OF CALCULATION

05.21.24

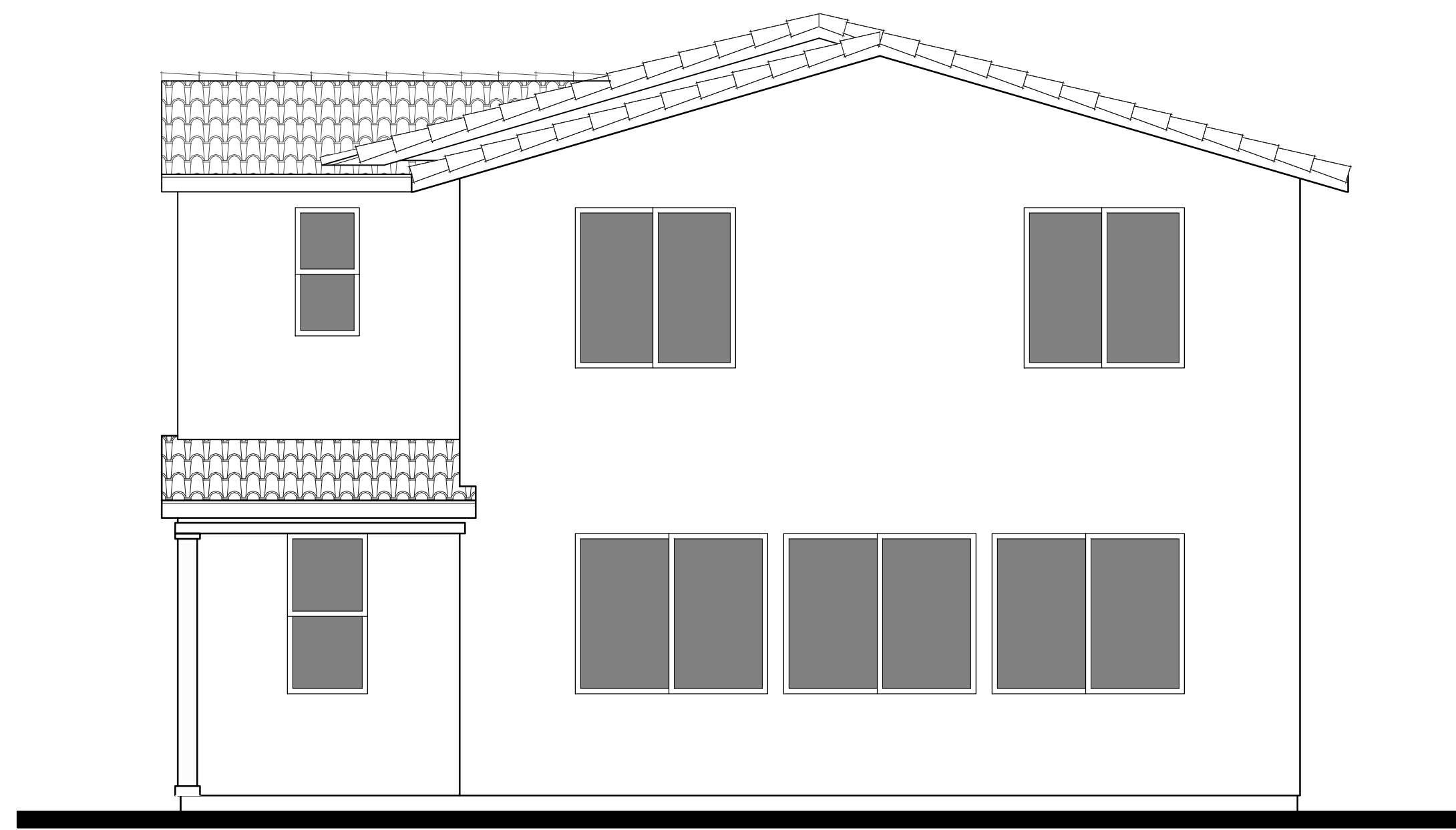

REAR



FRONT

A - SPANISH  
1/4"=1'-0"

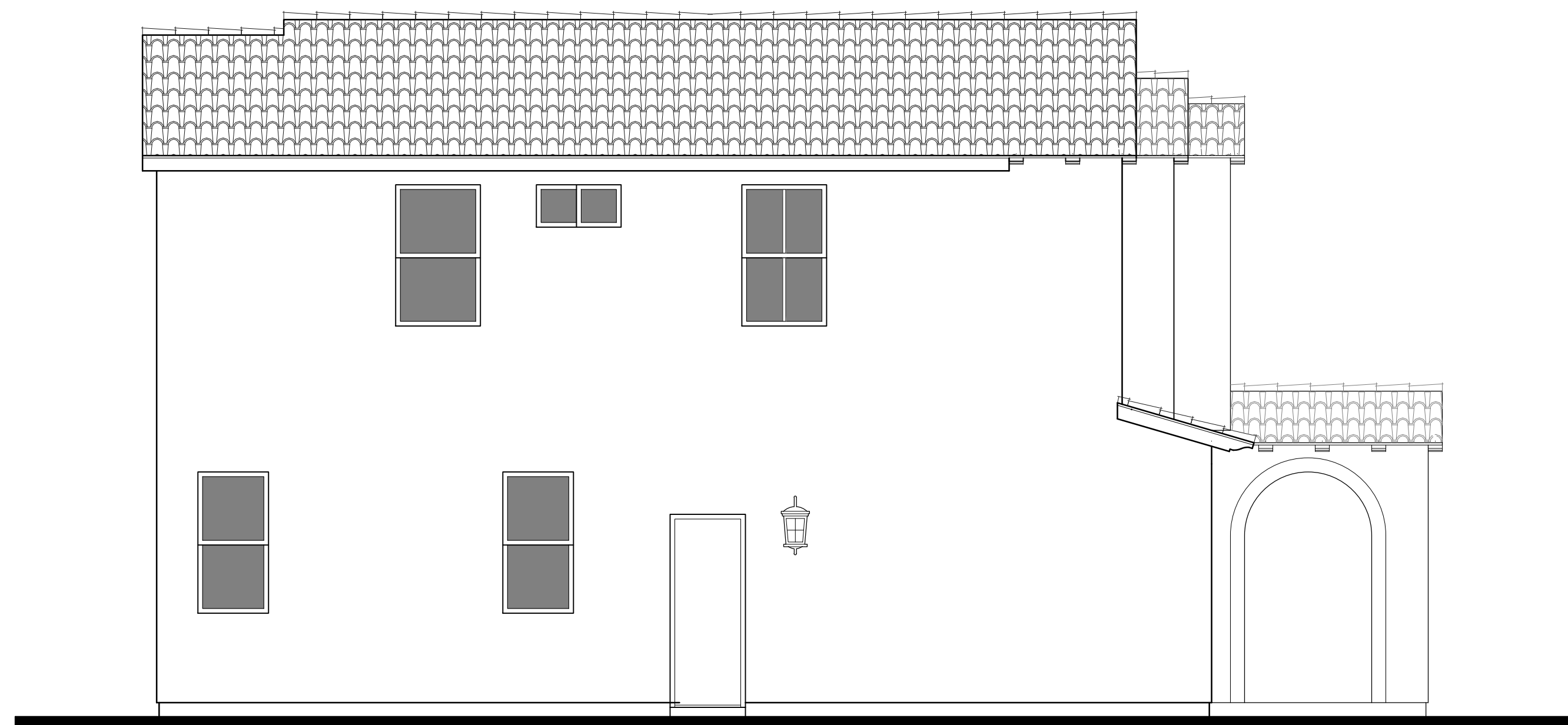
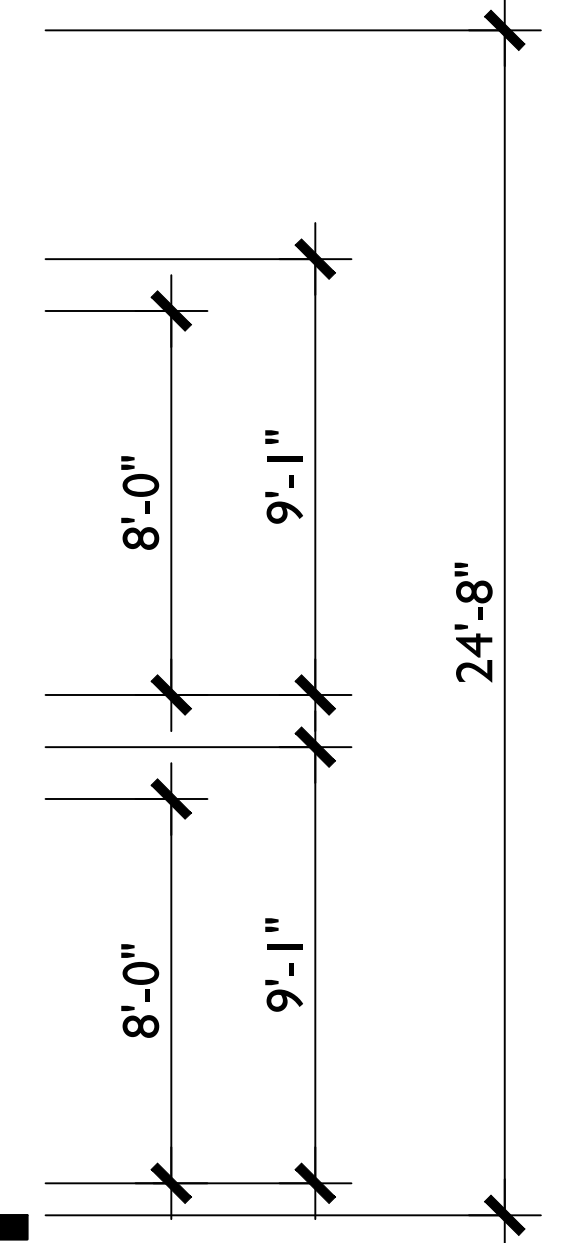

LEFT

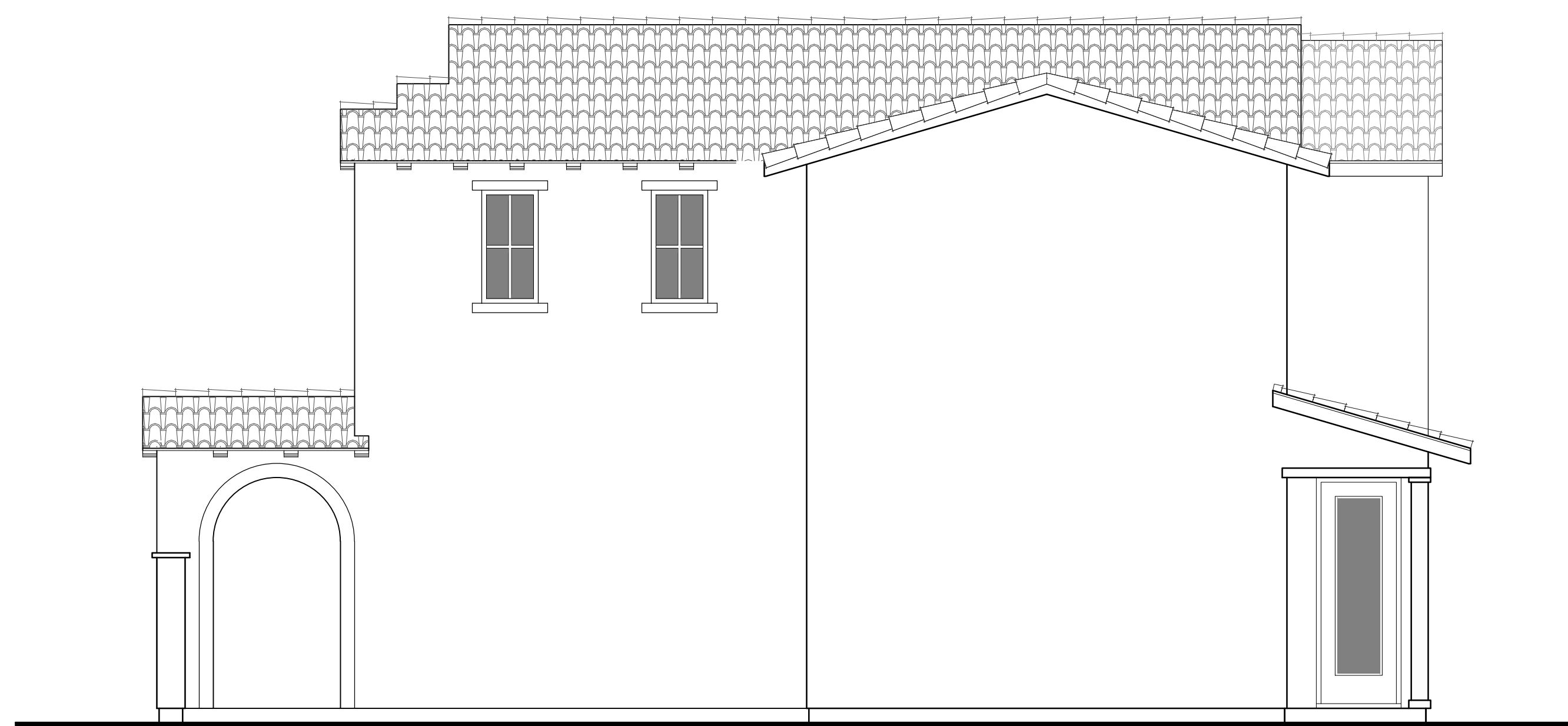

RIGHT

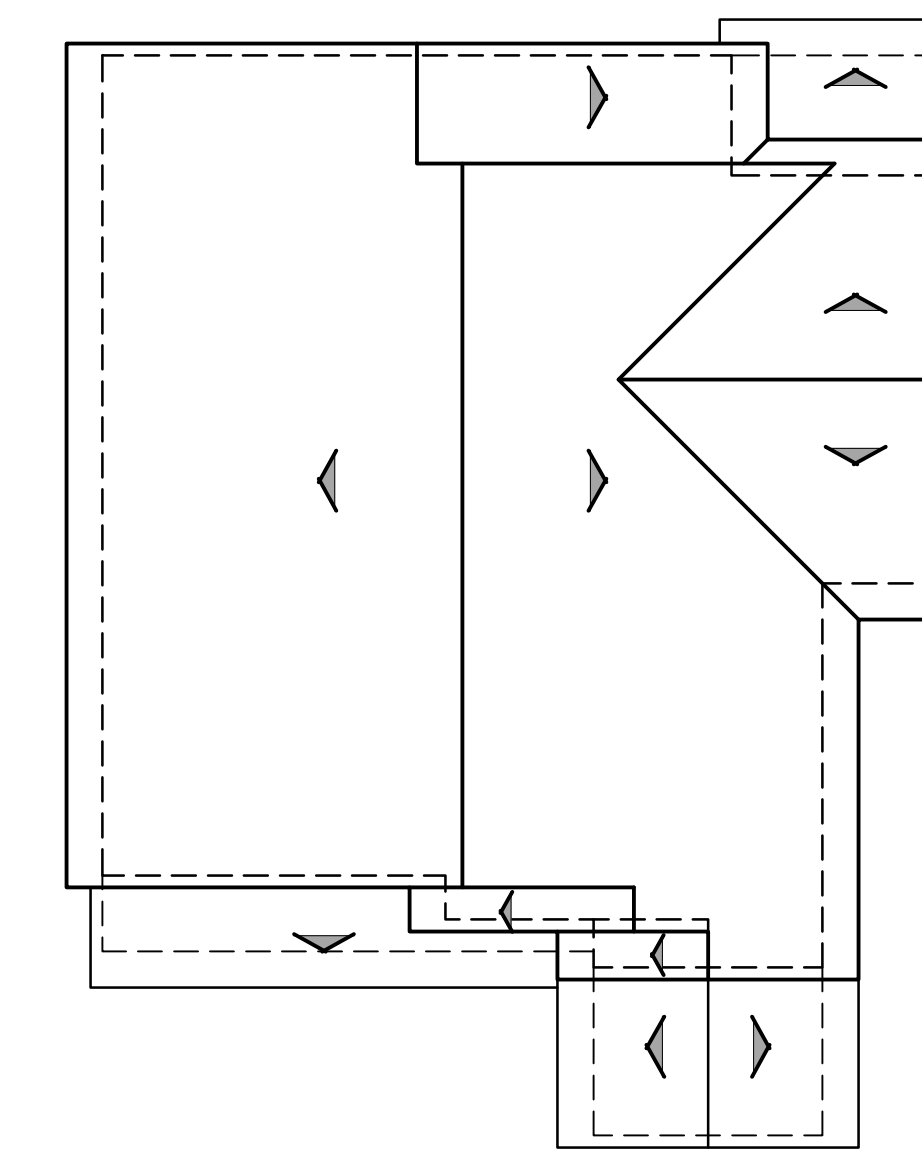

ROOF PLAN A  
PITCH: 3.5:12 U.N.O  
RAKE: 6"  
EAVE: 18"  
ROOF MATERIAL: CONCRETE 'S' TILE

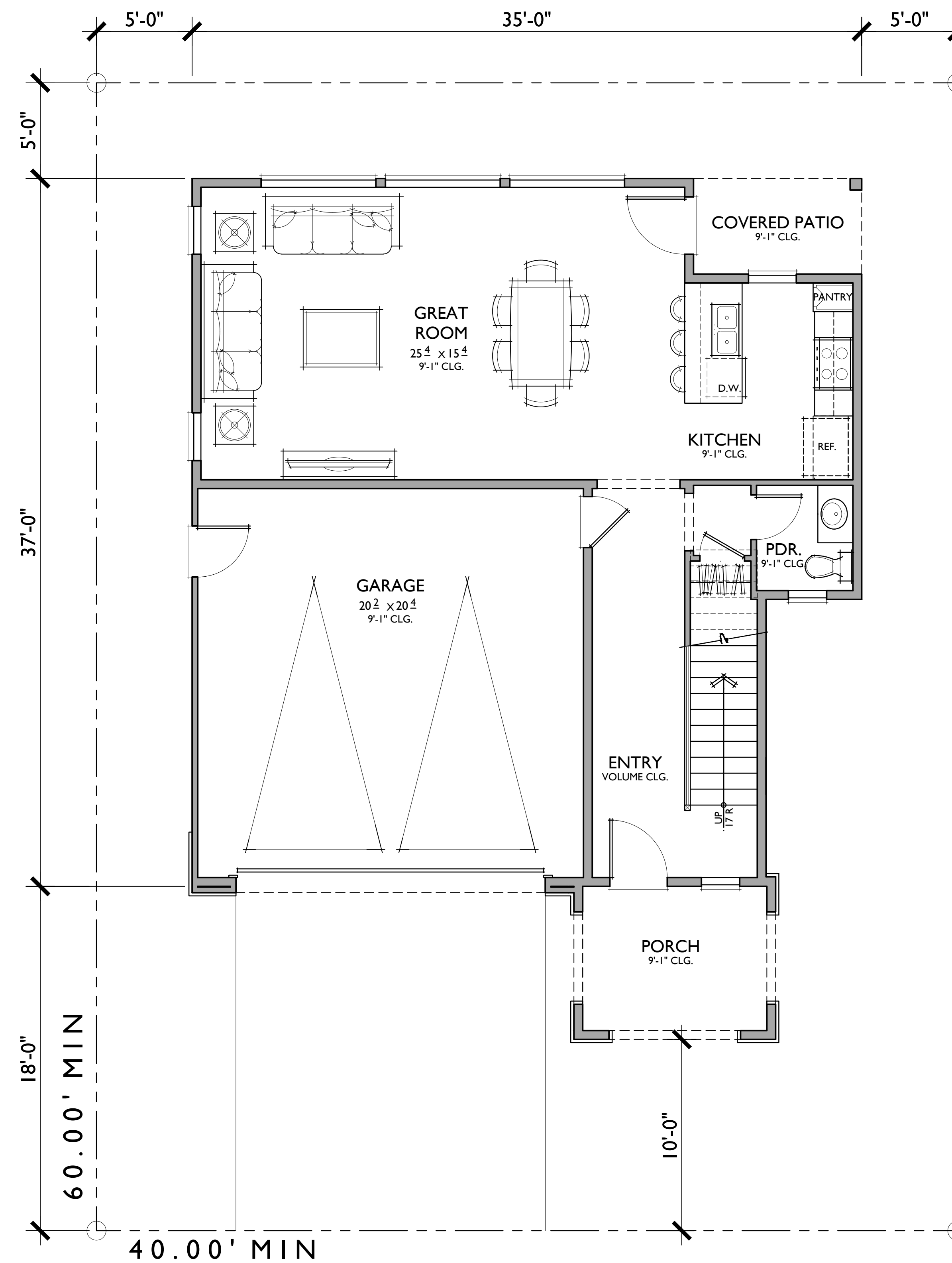
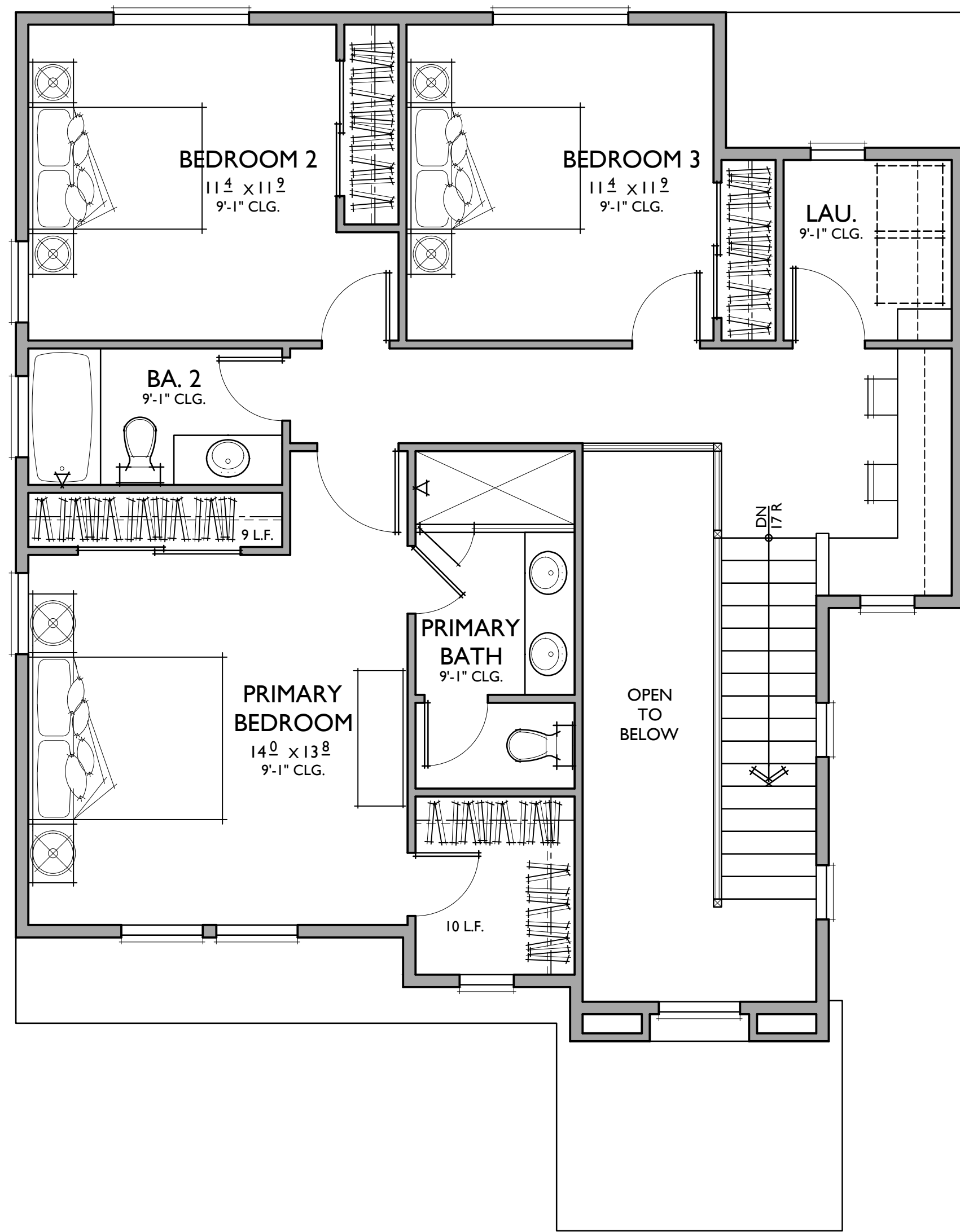

**PLAN I**

3 BEDROOMS / 2.5 BATHS  
2 - CAR GARAGE

**FLOOR AREA TABLE**

1ST FLOOR	751 SQ. FT.
2ND FLOOR	955 SQ. FT.
<b>TOTAL LIVING</b>	<b>1710 SQ. FT.</b>
2 - CAR GARAGE	425 SQ. FT.
COVERED PATIO	44 SQ. FT.
PORCH	84 SQ. FT.

NOTE: SQUARE FOOTAGE MAY VARY DUE TO METHOD OF CALCULATION

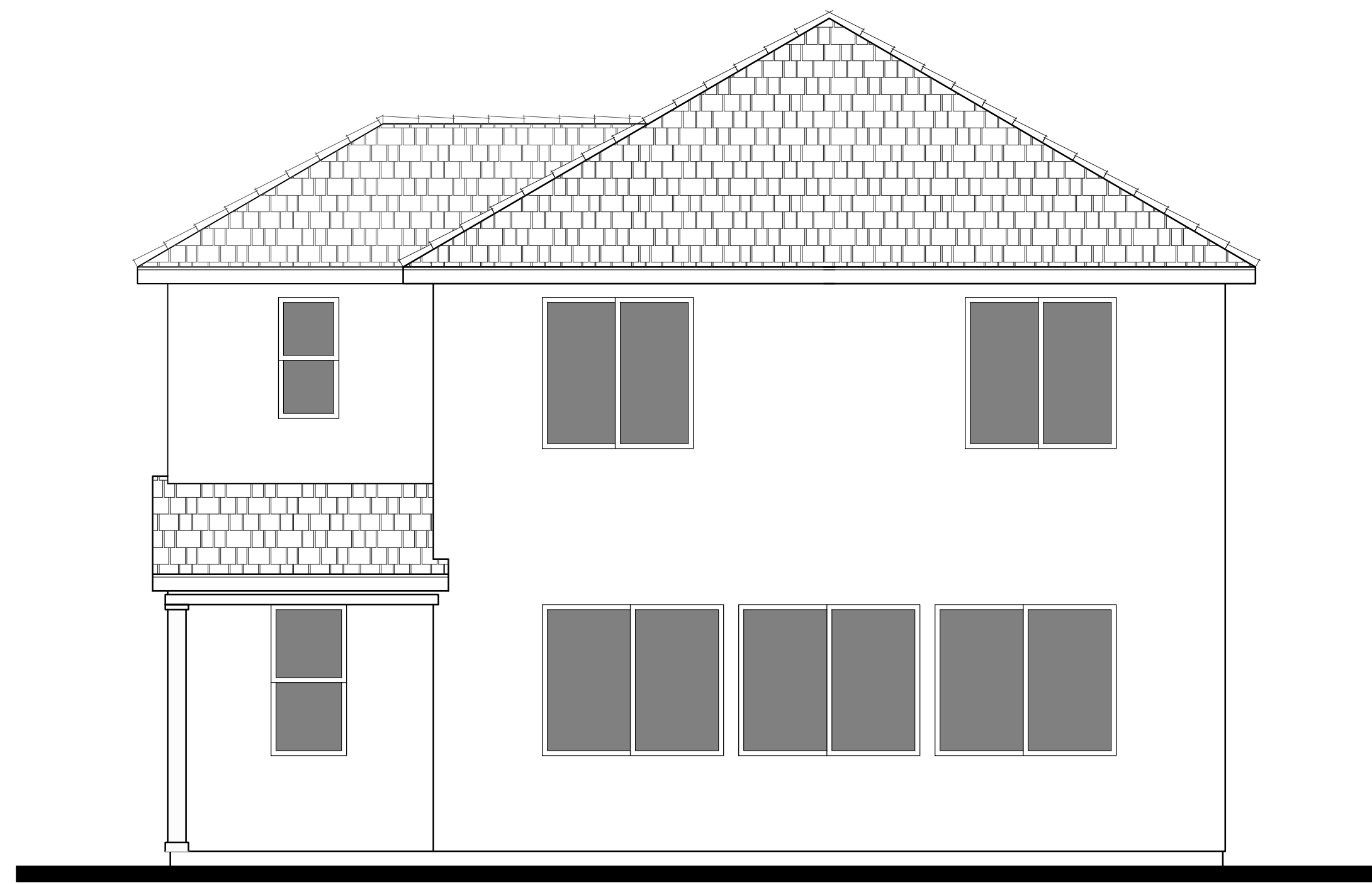

REAR



FRONT

B - FRENCH COUNTRY  
1/4"=1'-0"



LEFT

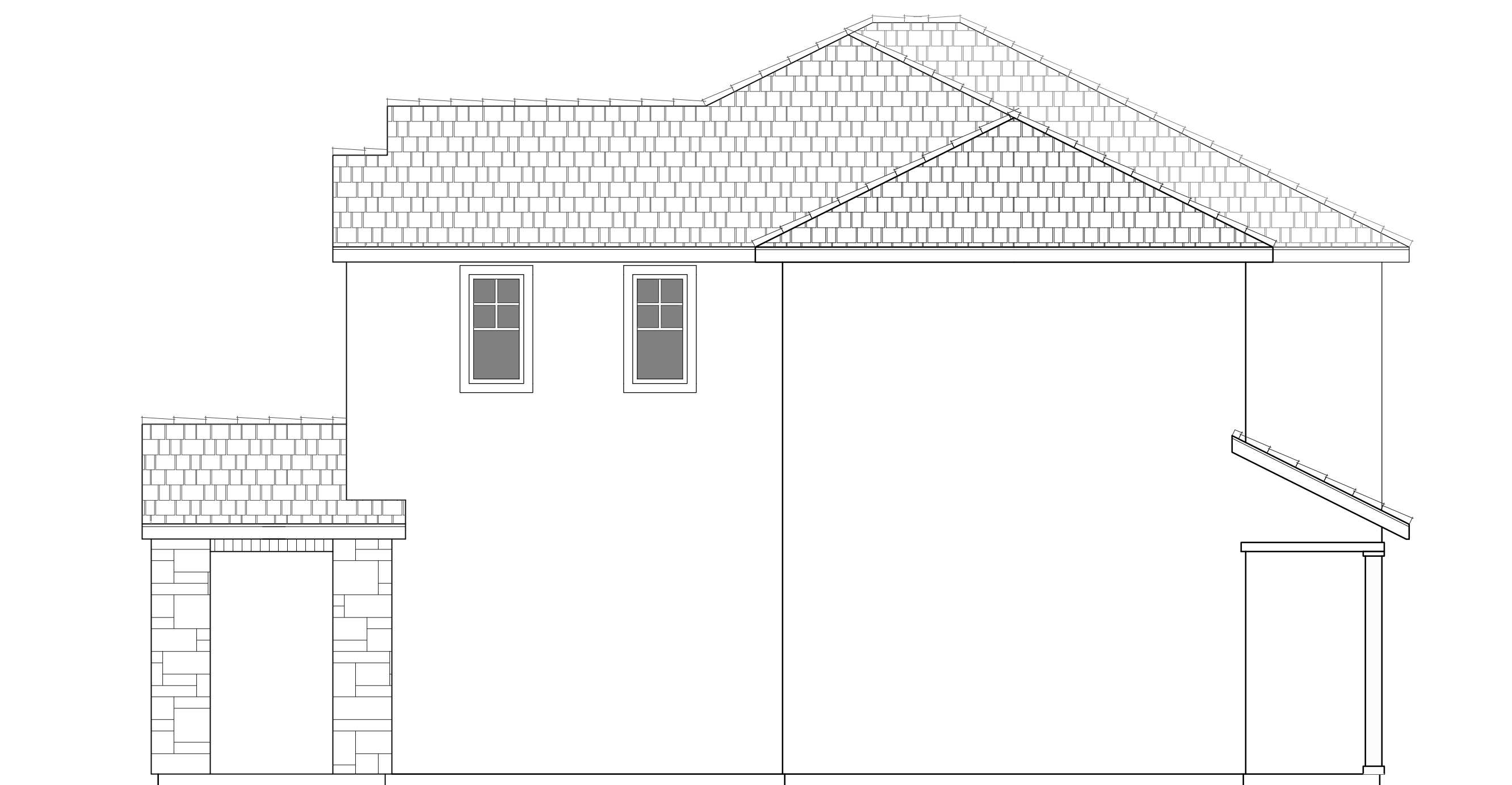

RIGHT

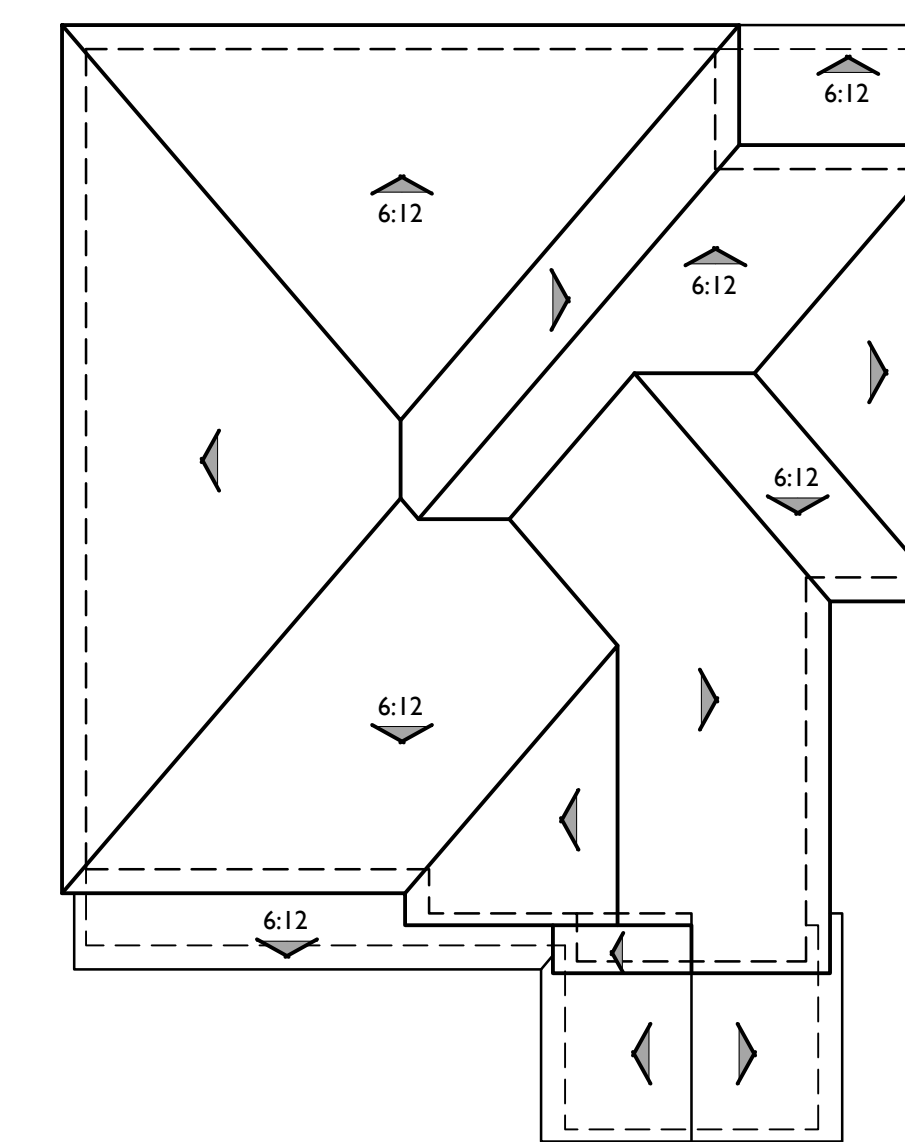

ROOF PLAN B

PITCH: 7:12 U.N.O  
RAKE: 6"  
EAVE: 12"  
ROOF MATERIAL: CONCRETE FLAT TILE



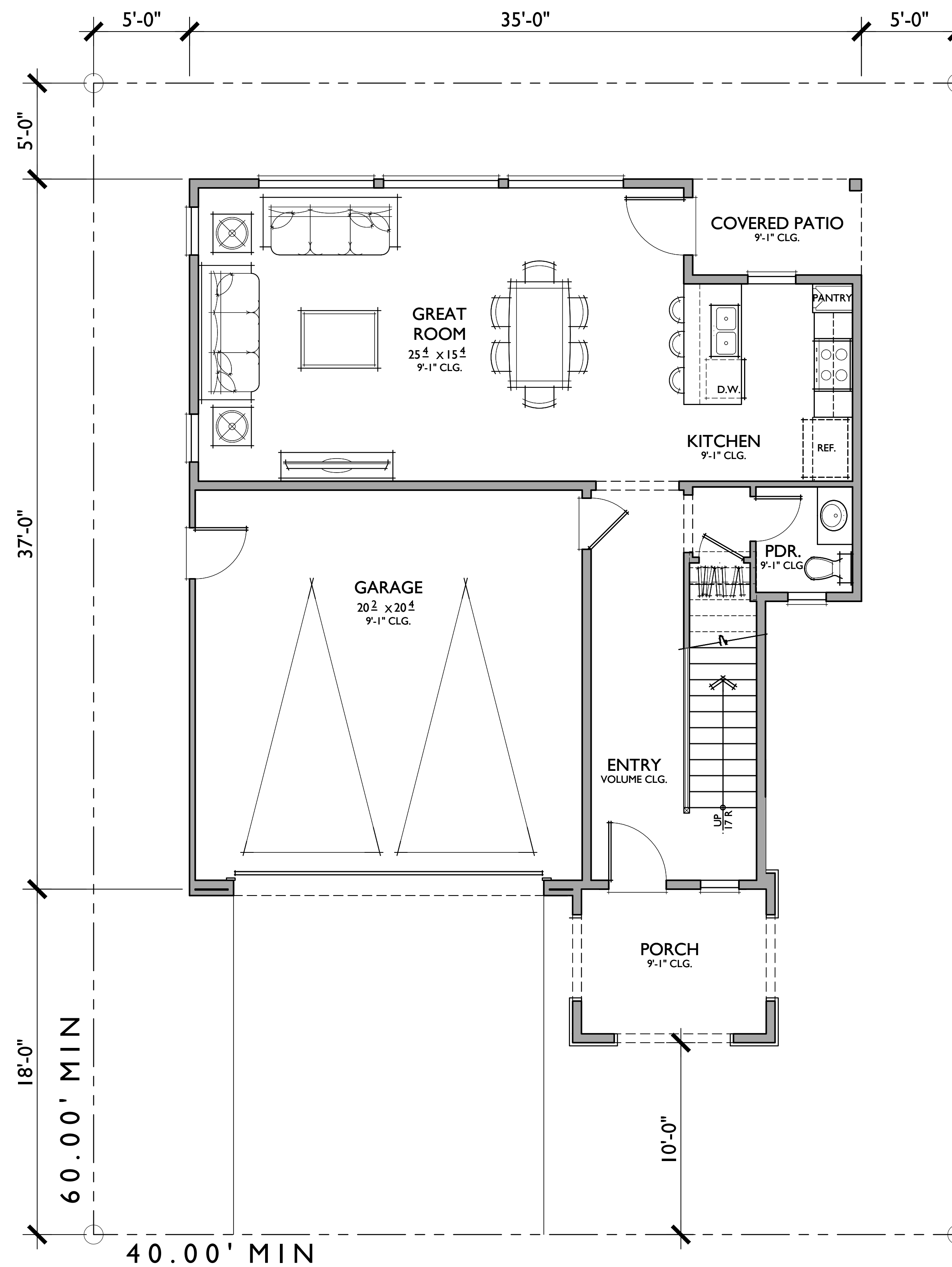
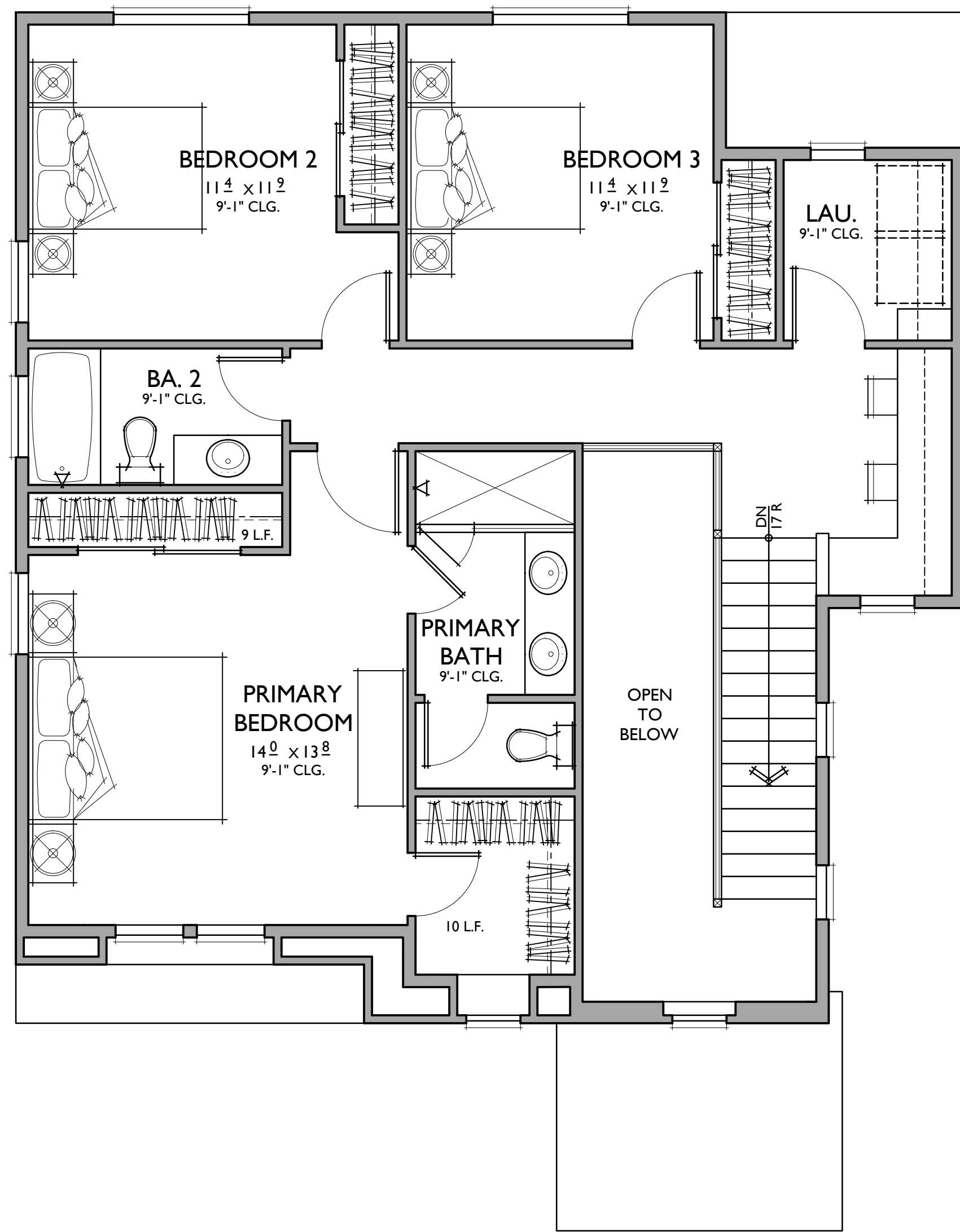

**PLAN I**

3 BEDROOMS / 2.5 BATHS  
2 - CAR GARAGE

**FLOOR AREA TABLE**

1ST FLOOR	751 SQ. FT.
2ND FLOOR	955 SQ. FT.
<b>TOTAL LIVING</b>	<b>1710 SQ. FT.</b>
2 - CAR GARAGE	425 SQ. FT.
COVERED PATIO	44 SQ. FT.
PORCH	84 SQ. FT.

NOTE: SQUARE FOOTAGE MAY VARY DUE TO METHOD OF CALCULATION

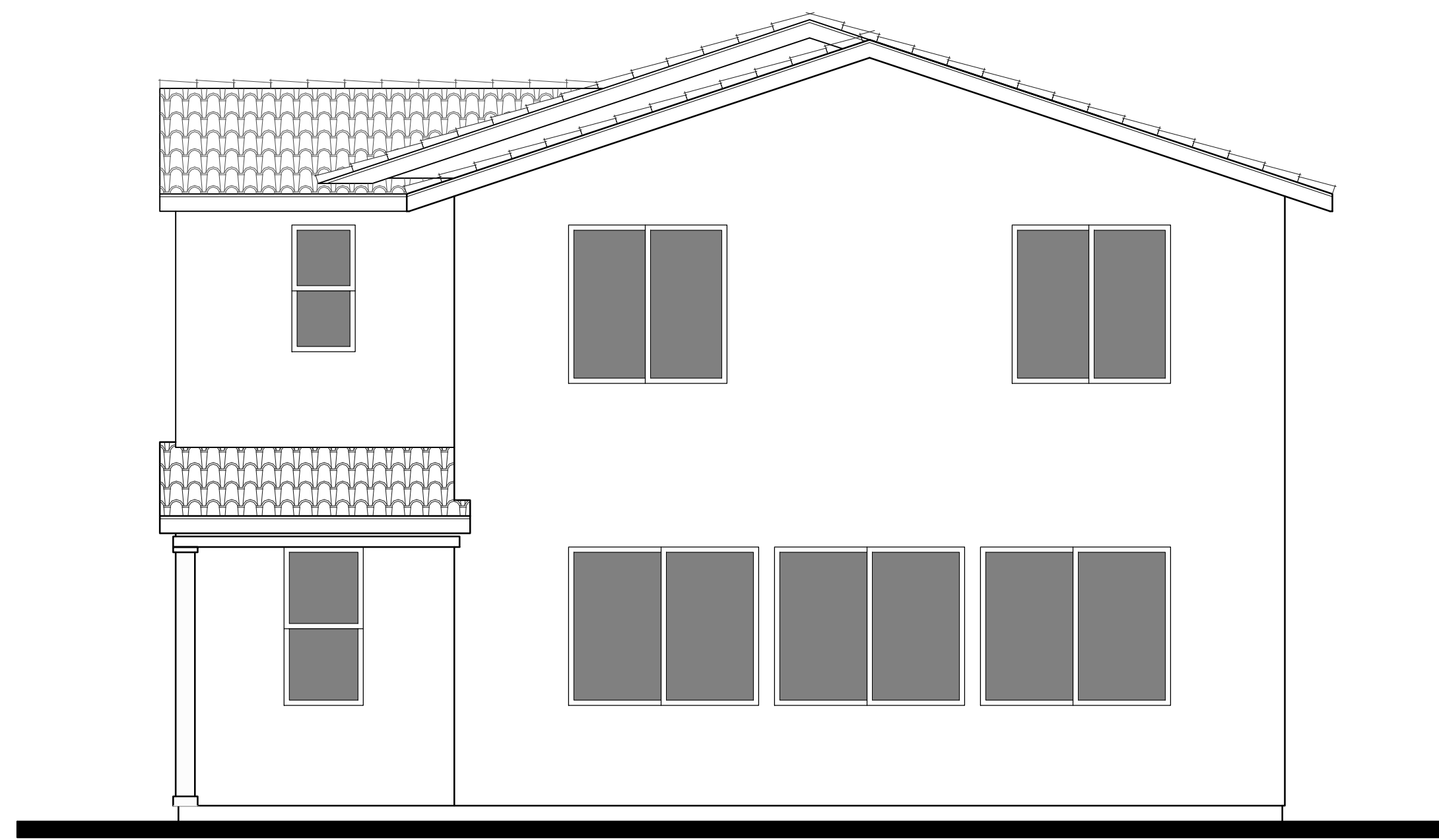

REAR



FRONT

C - TUSCAN  
1/4"=1'-0"

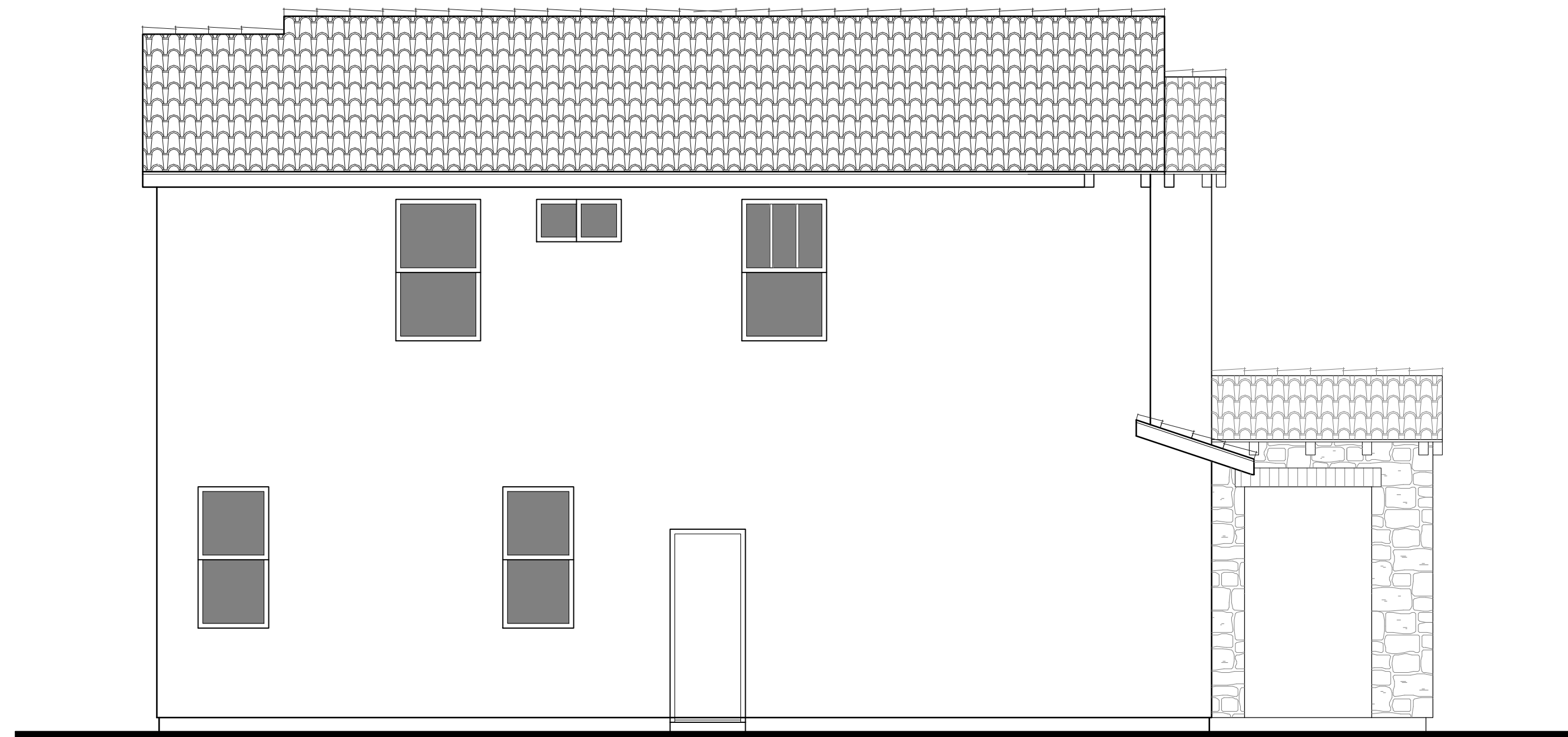
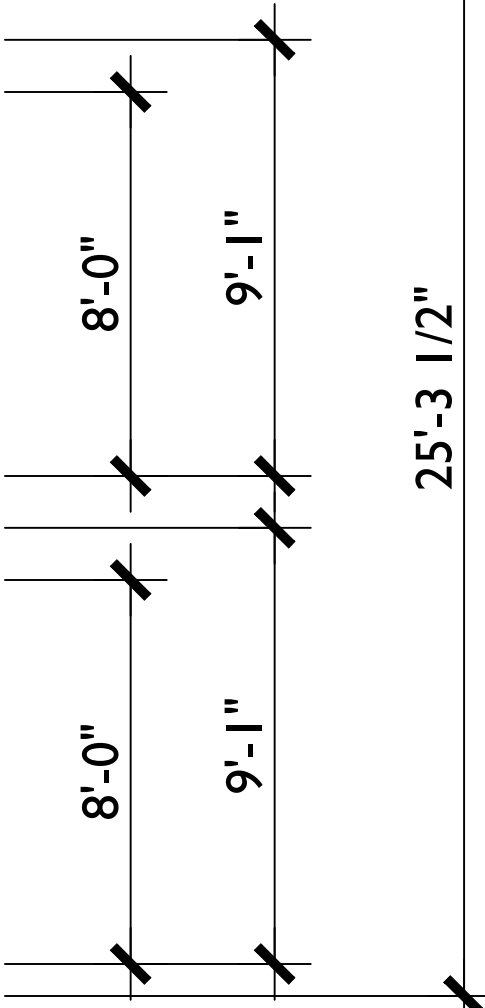

LEFT

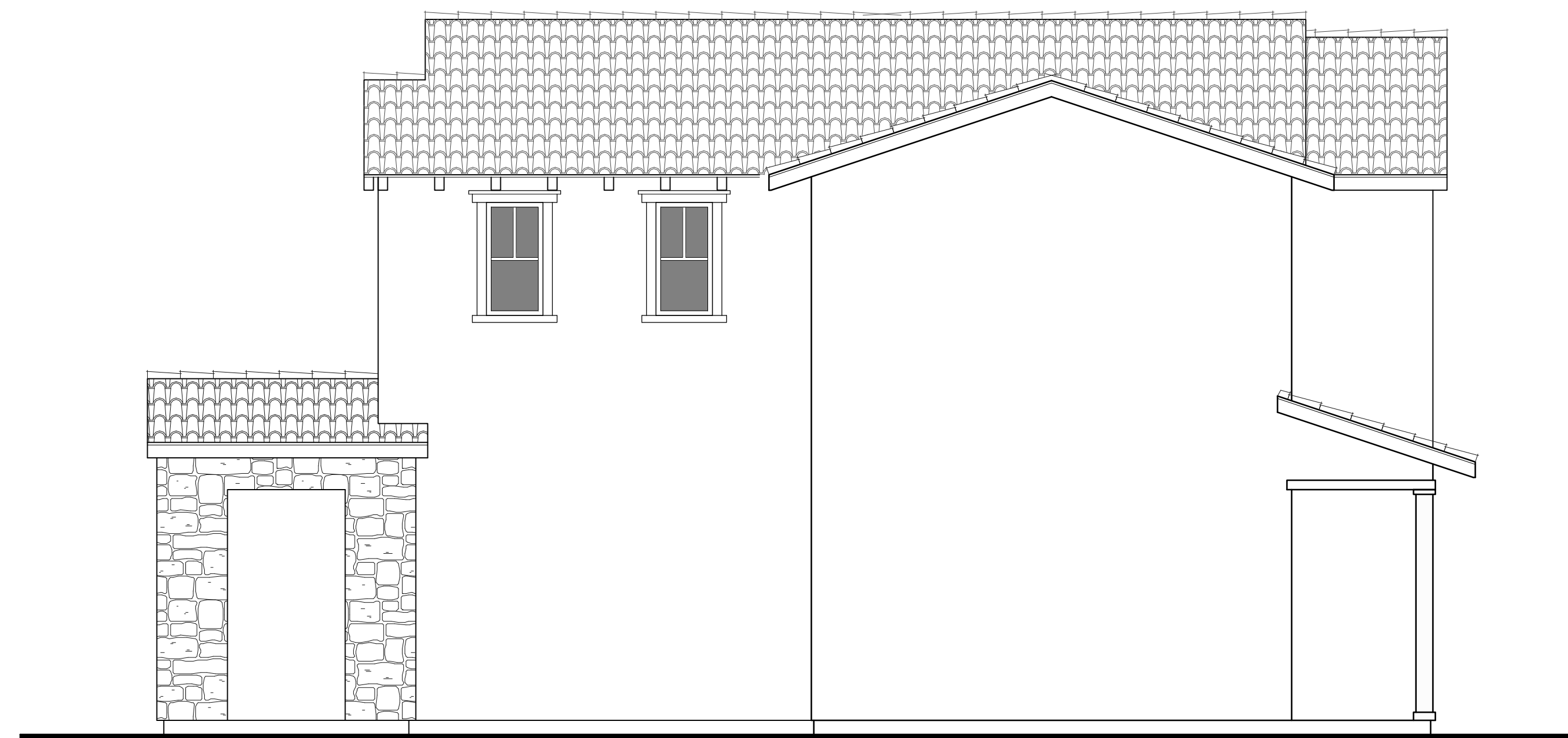

RIGHT

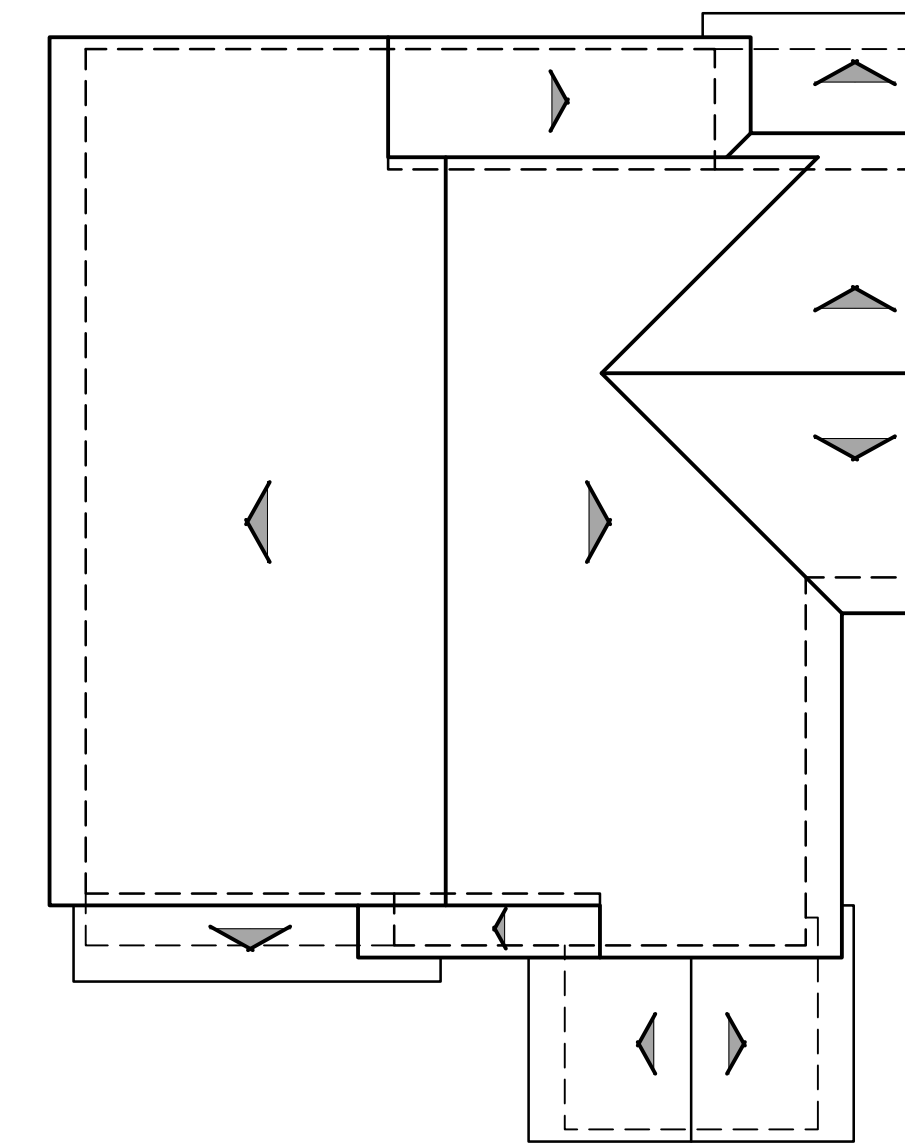

ROOF PLAN C

PITCH: 4:12 U.N.O  
RAKE: 6"  
EAVE: 18"  
ROOF MATERIAL: CONCRETE 'S' TILE



SPANISH



FRENCH COUNTRY



TUSCAN

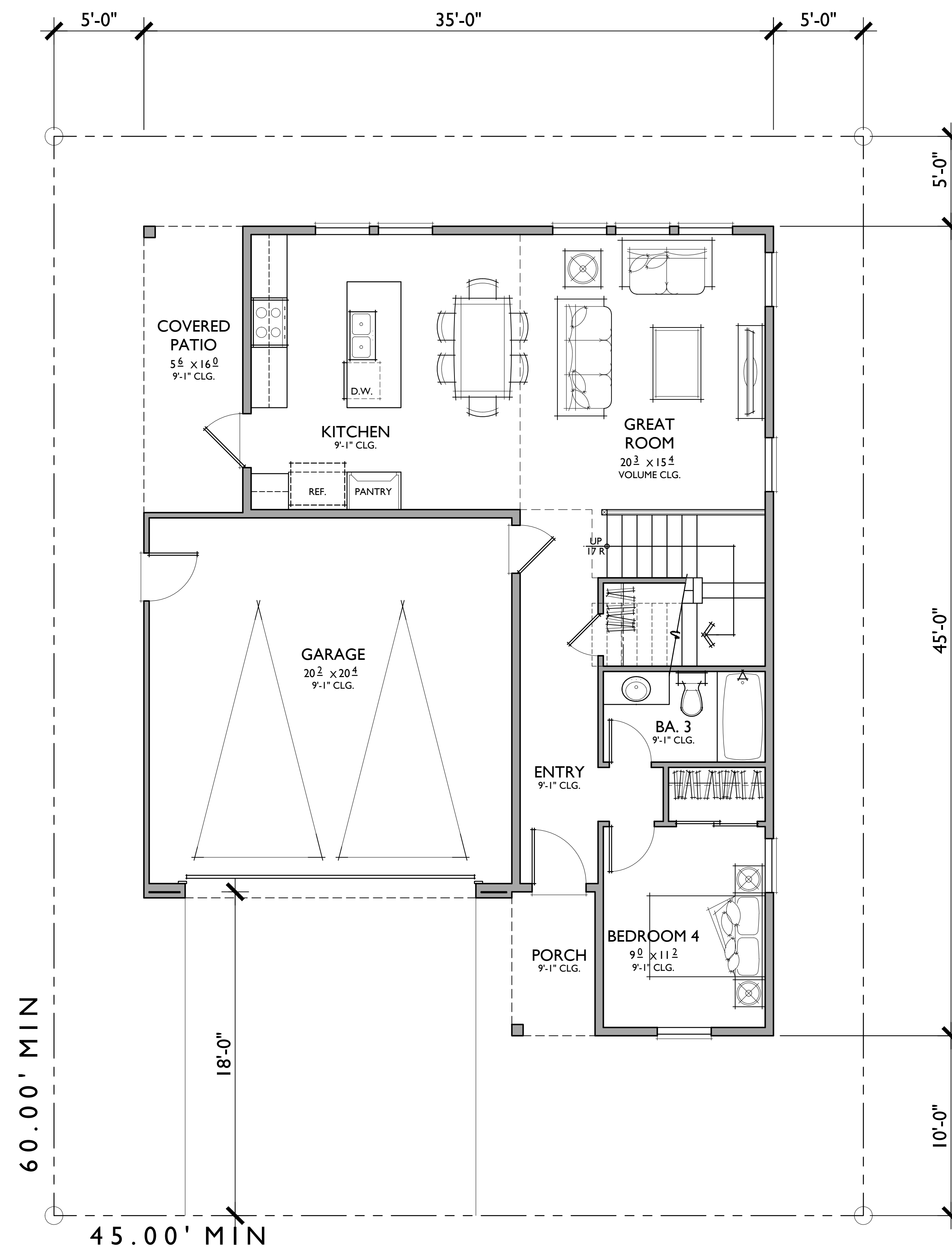
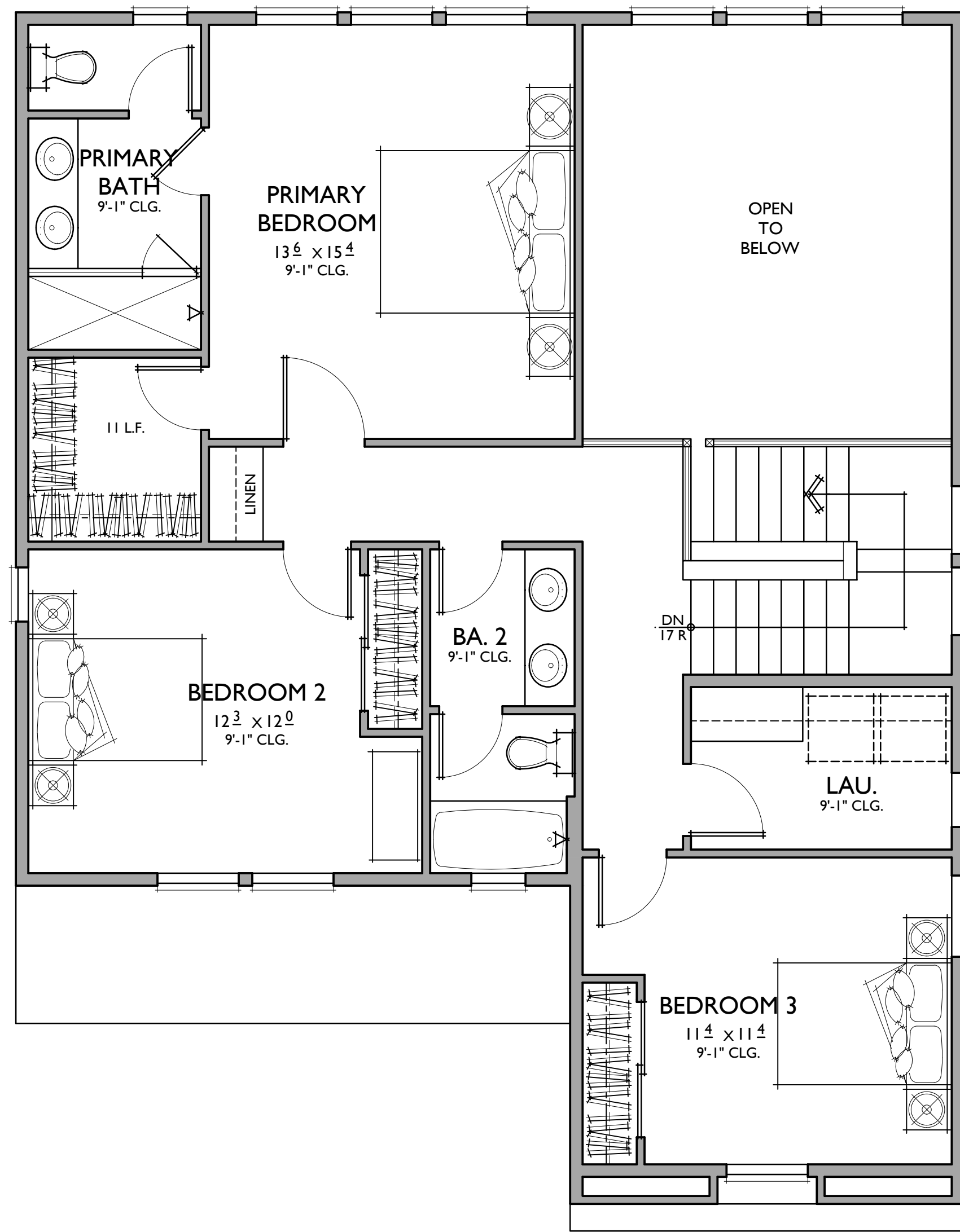

**PLAN 2**

4 BEDROOMS / 3 BATHS  
2 - CAR GARAGE

FLOOR AREA TABLE	
1ST FLOOR	860 SQ. FT.
2ND FLOOR	975 SQ. FT.
<b>TOTAL LIVING</b>	<b>1835 SQ. FT.</b>
2 - CAR GARAGE	427 SQ. FT.
COVERED PATIO	88 SQ. FT.
PORCH	37 SQ. FT.

NOTE: SQUARE FOOTAGE MAY VARY DUE TO METHOD OF CALCULATION

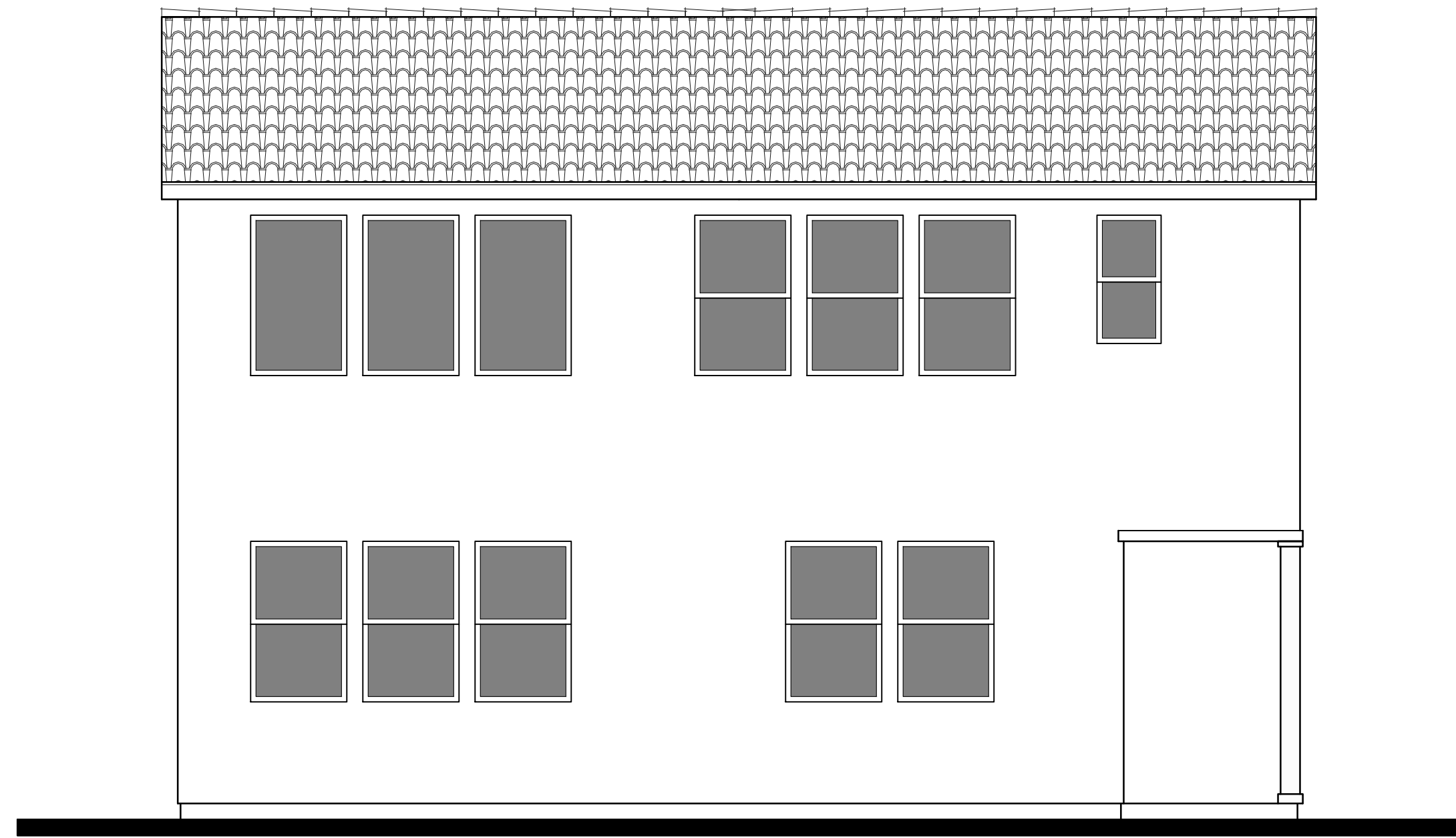

REAR



FRONT

A - SPANISH  
1/4"=1'-0"

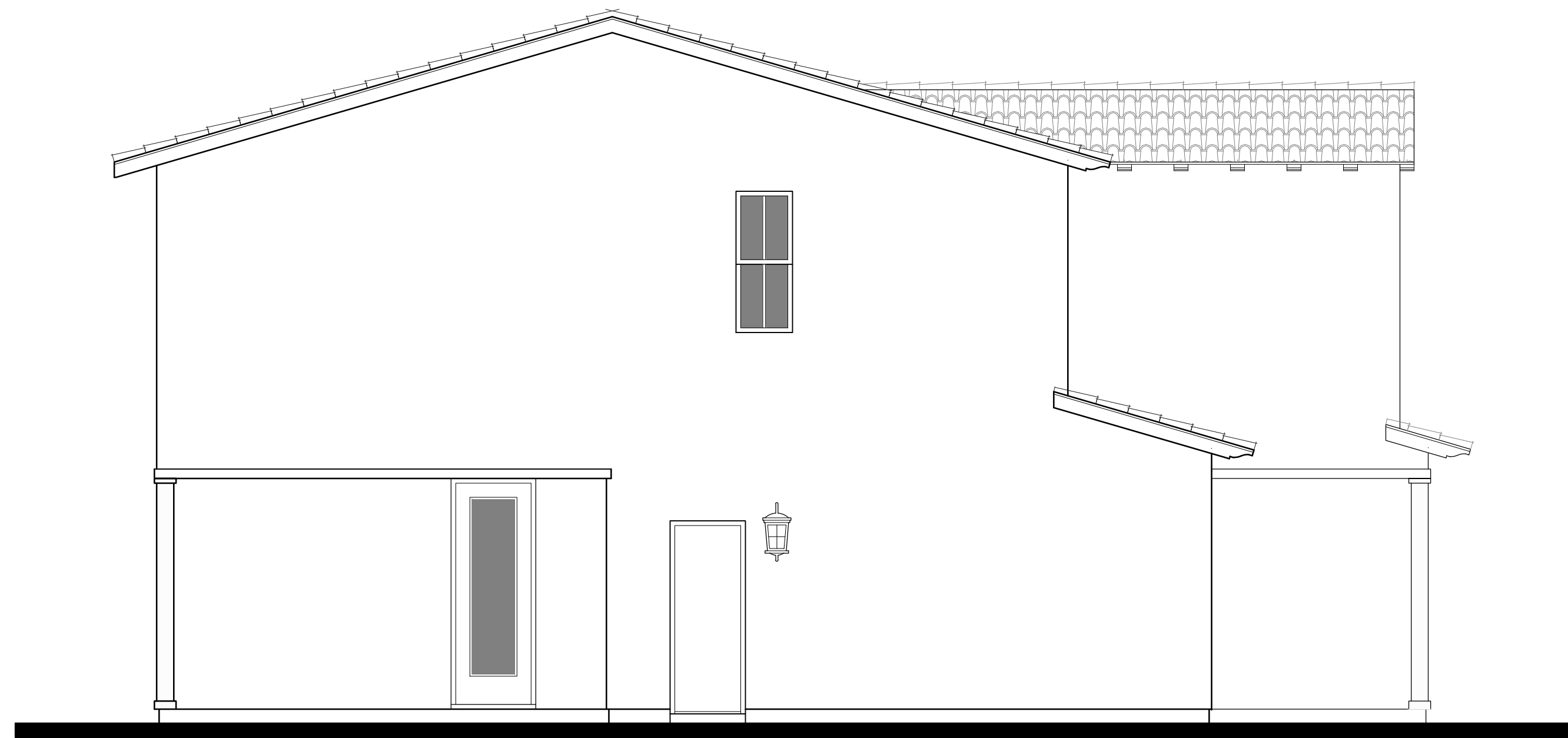

LEFT

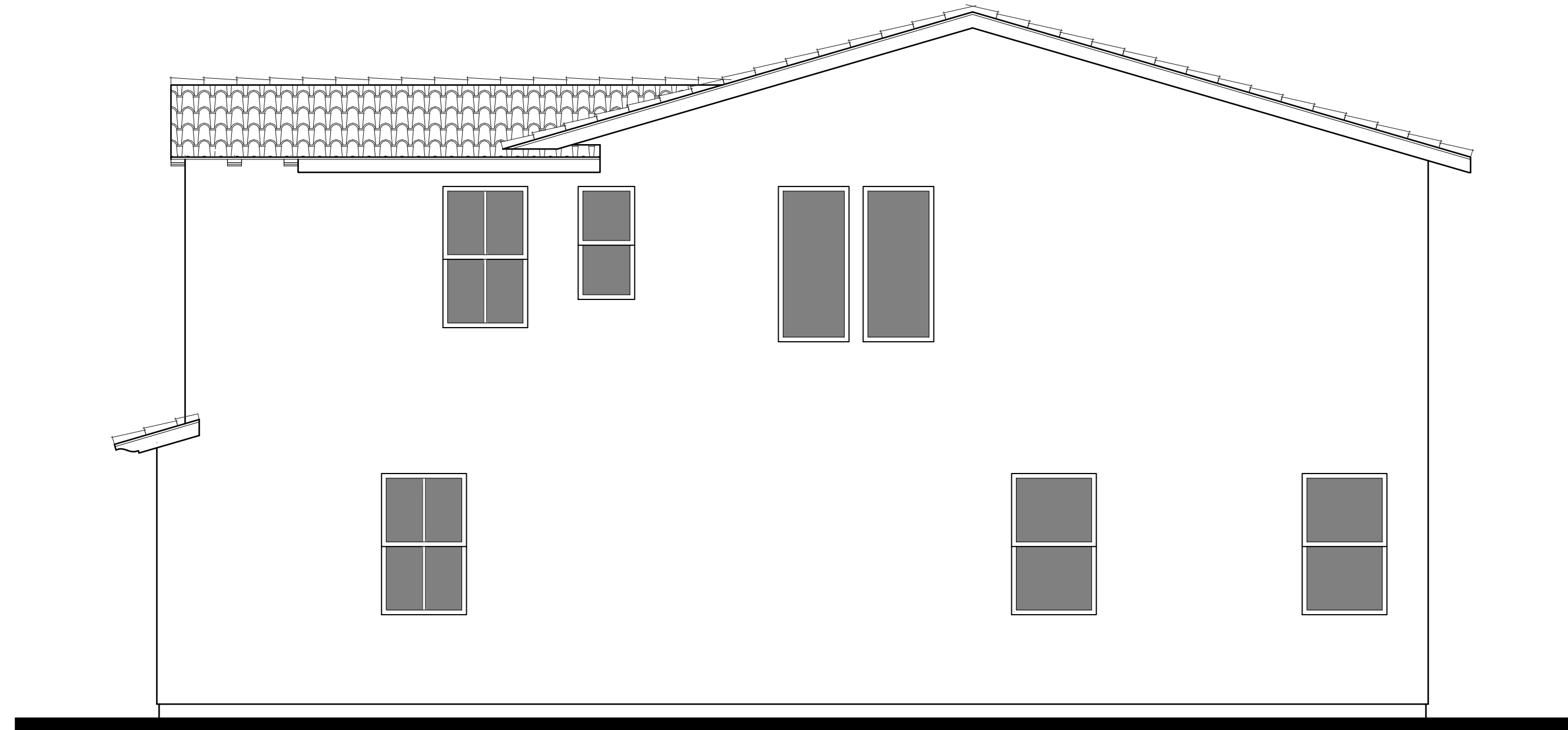

RIGHT

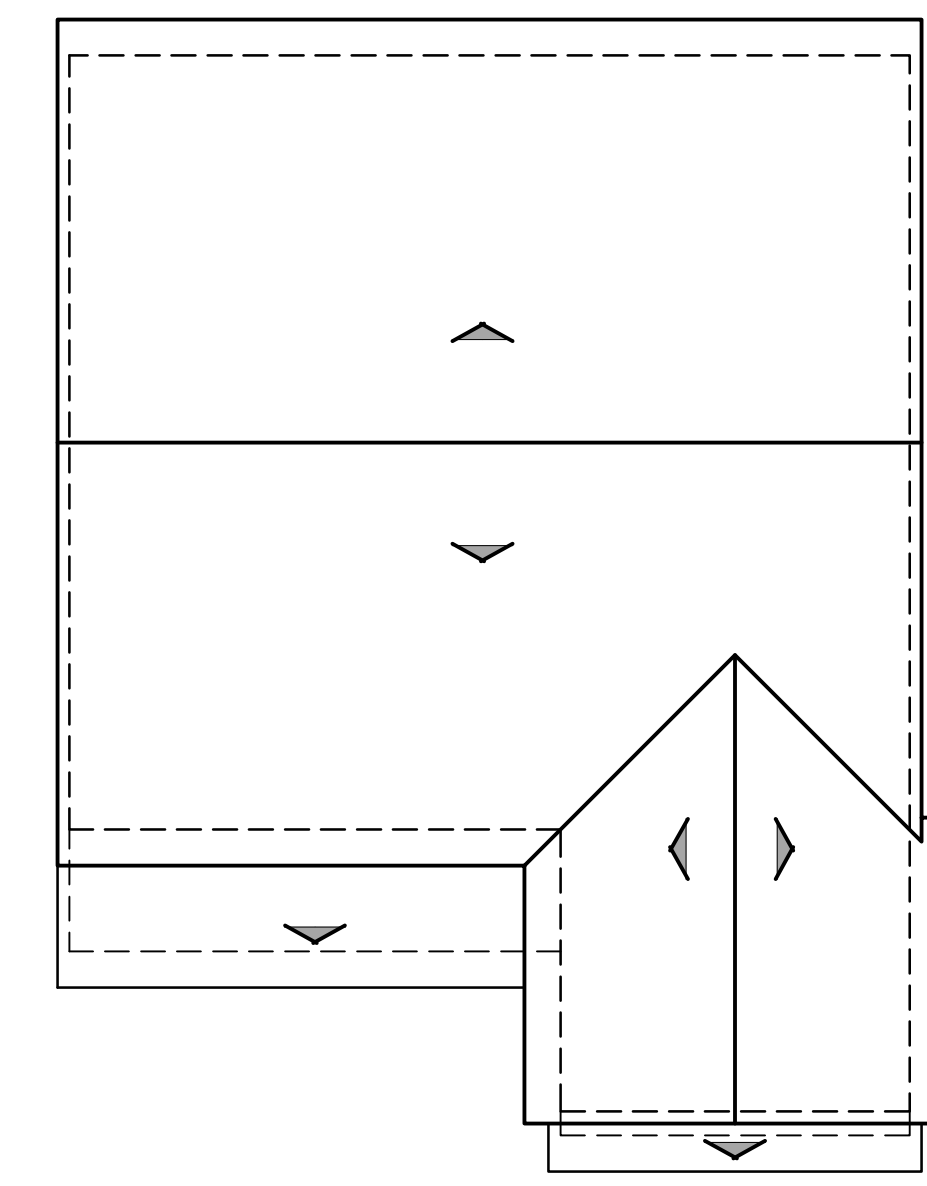

ROOF PLAN

A

PITCH: 3.5:12 U.N.O  
RAKE: 6"  
EAVE: 18"  
ROOF MATERIAL: CONCRETE 'S' TILE

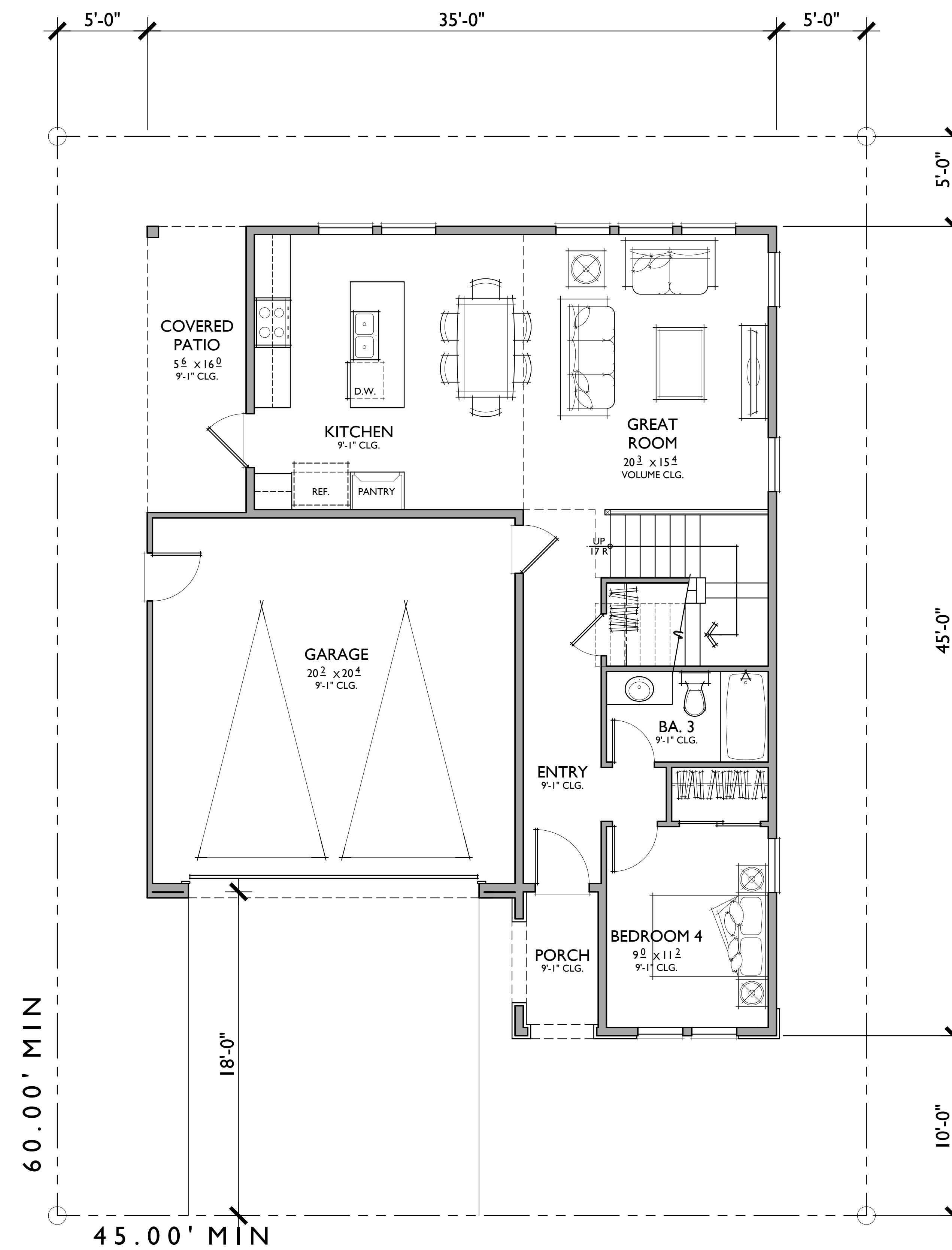
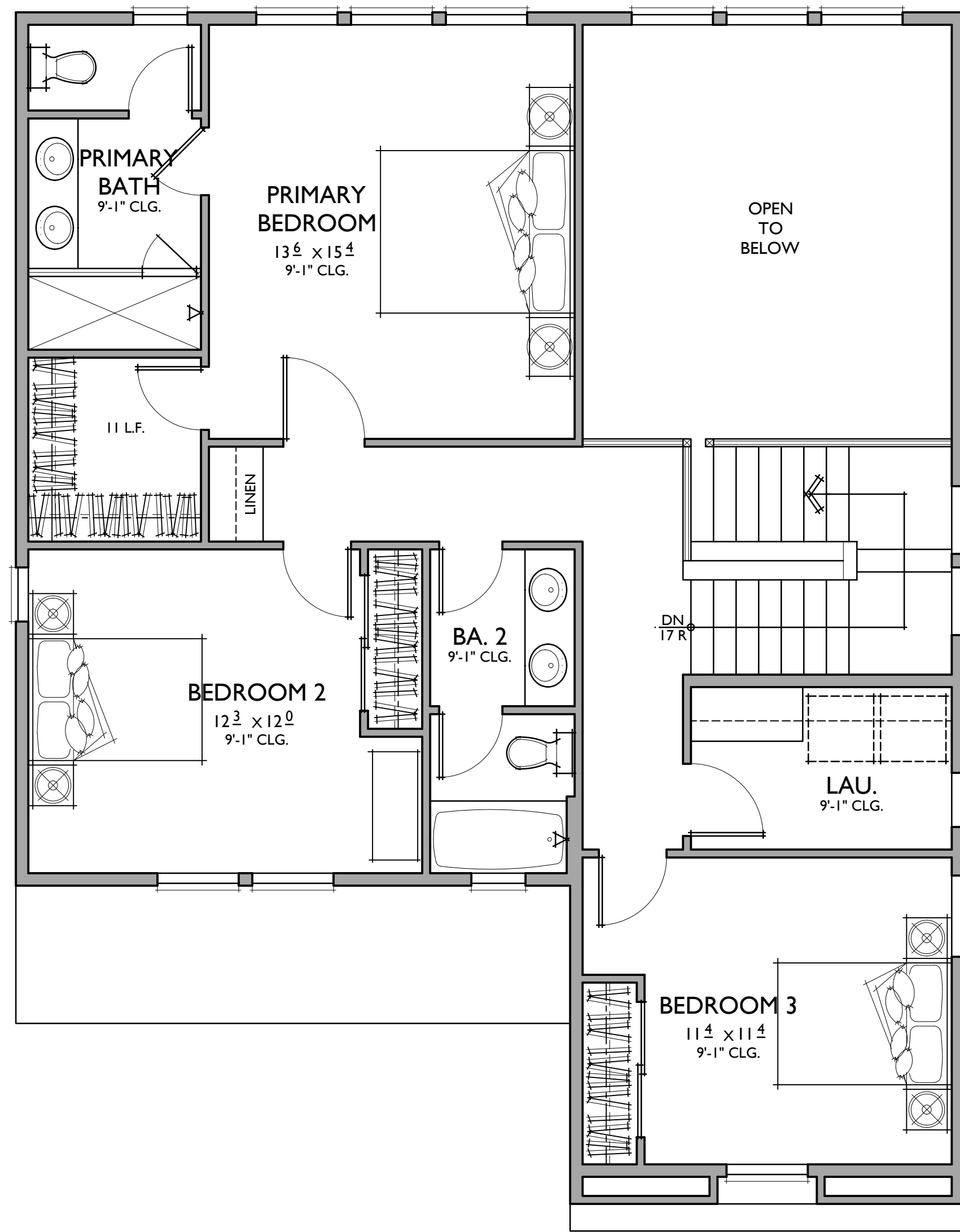

**PLAN 2**  
 4 BEDROOMS / 3 BATHS  
 2 - CAR GARAGE

FLOOR AREA TABLE	
1ST FLOOR	860 SQ. FT.
2ND FLOOR	975 SQ. FT.
<b>TOTAL LIVING</b>	<b>1835 SQ. FT.</b>
2 - CAR GARAGE	427 SQ. FT.
COVERED PATIO	88 SQ. FT.
PORCH	37 SQ. FT.

NOTE: SQUARE FOOTAGE MAY VARY DUE TO METHOD OF CALCULATION

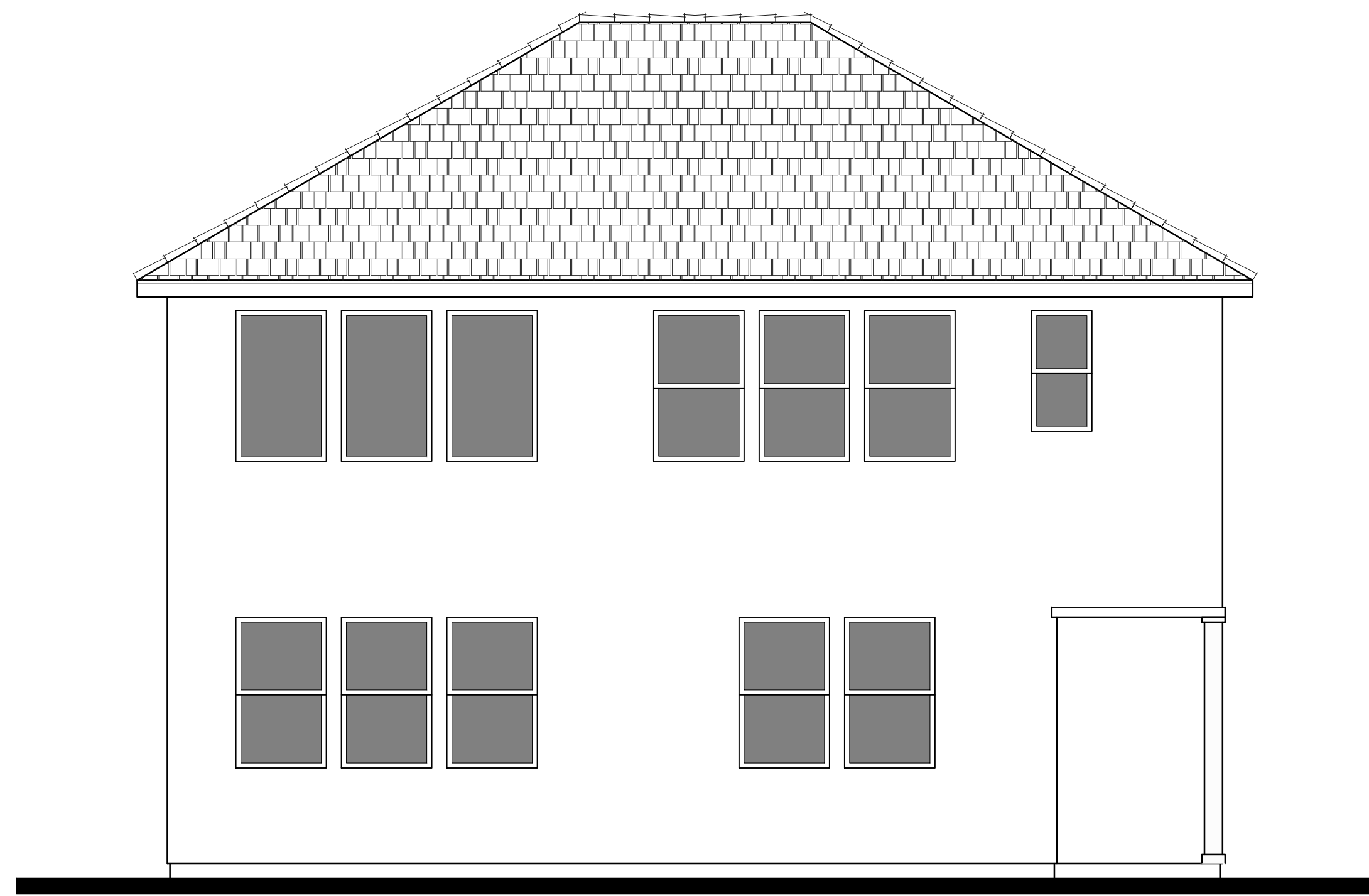

REAR



FRONT

B - FRENCH COUNTRY  
1/4"=1'-0"

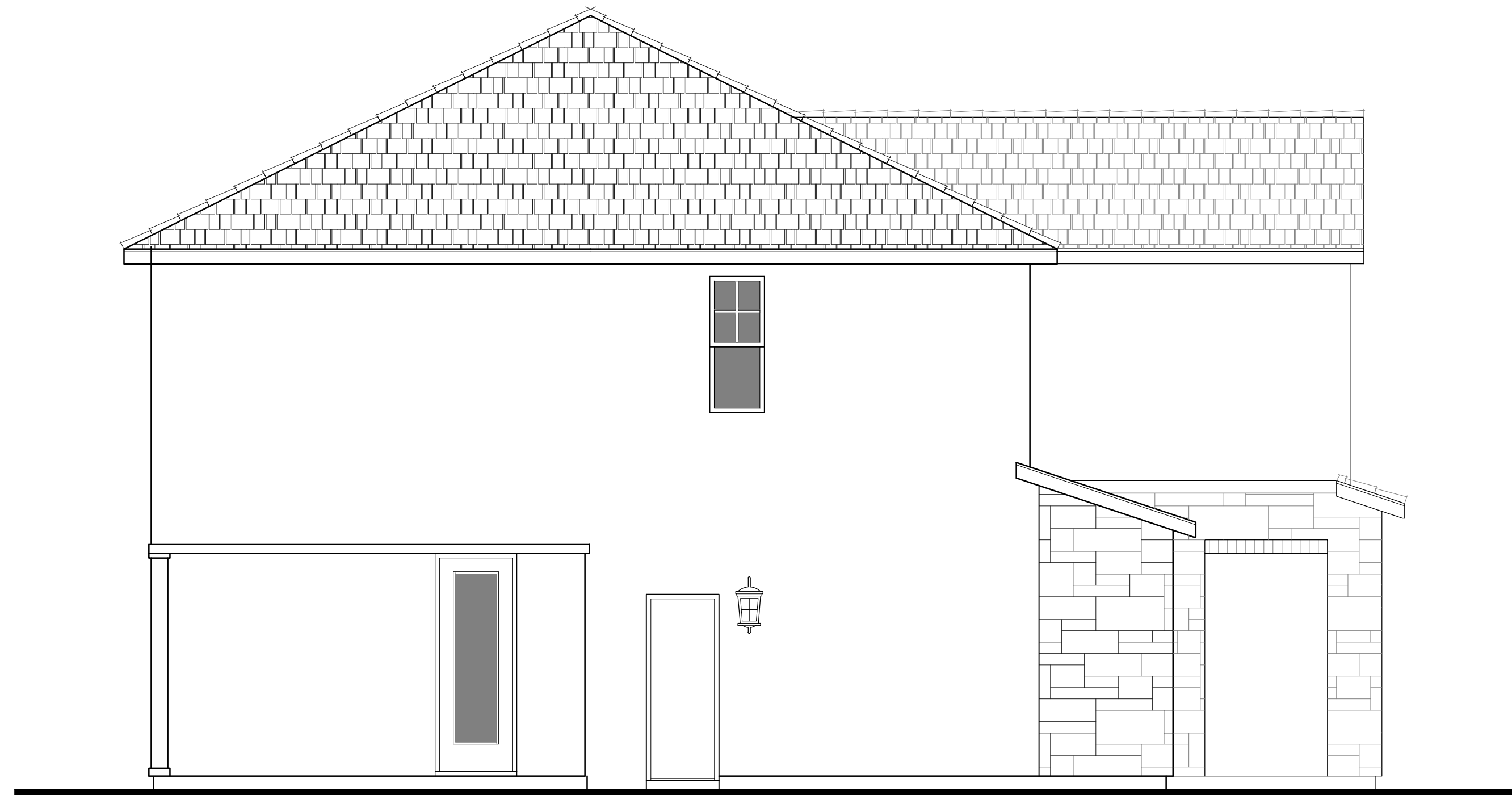

LEFT

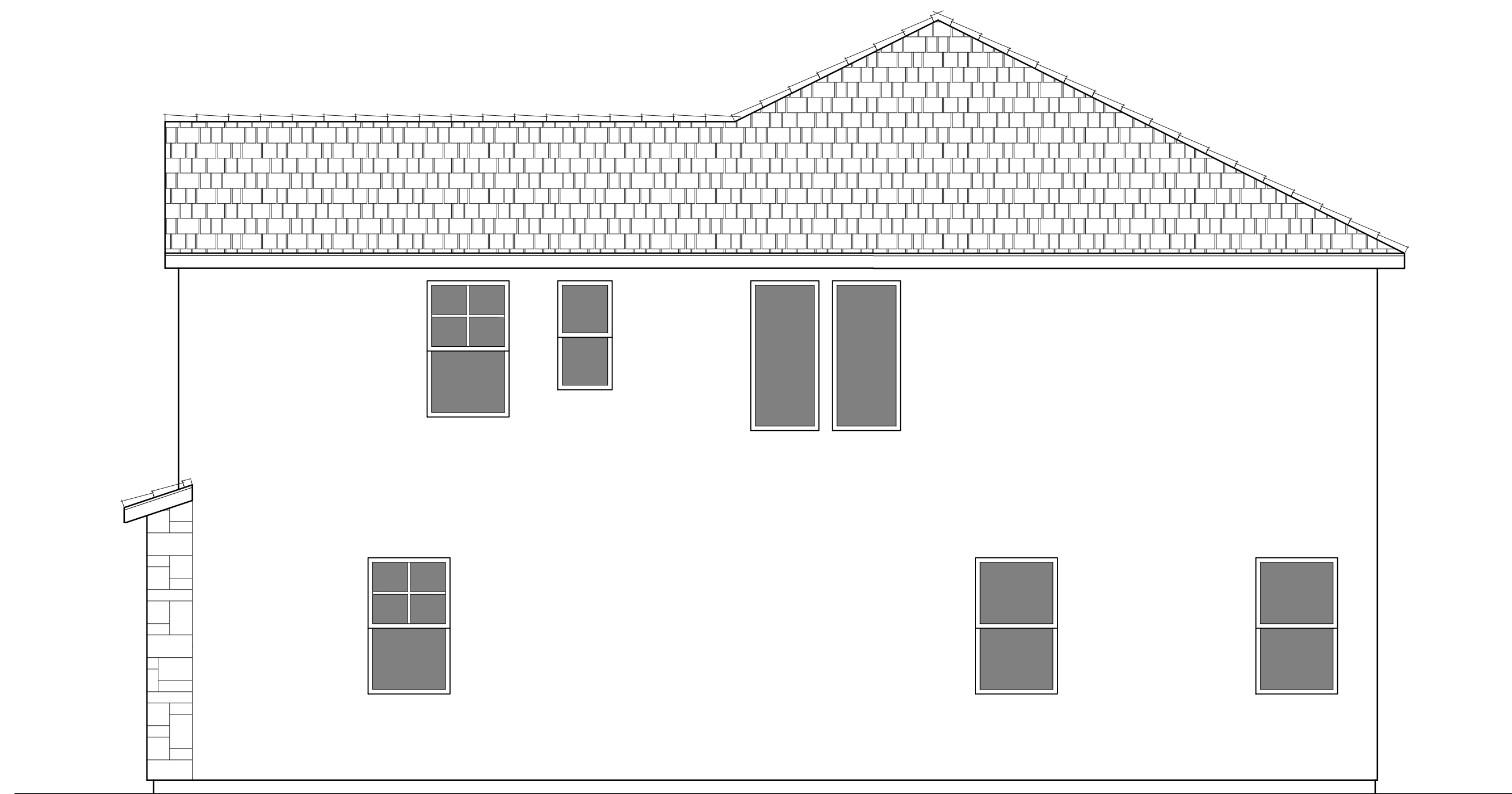

RIGHT

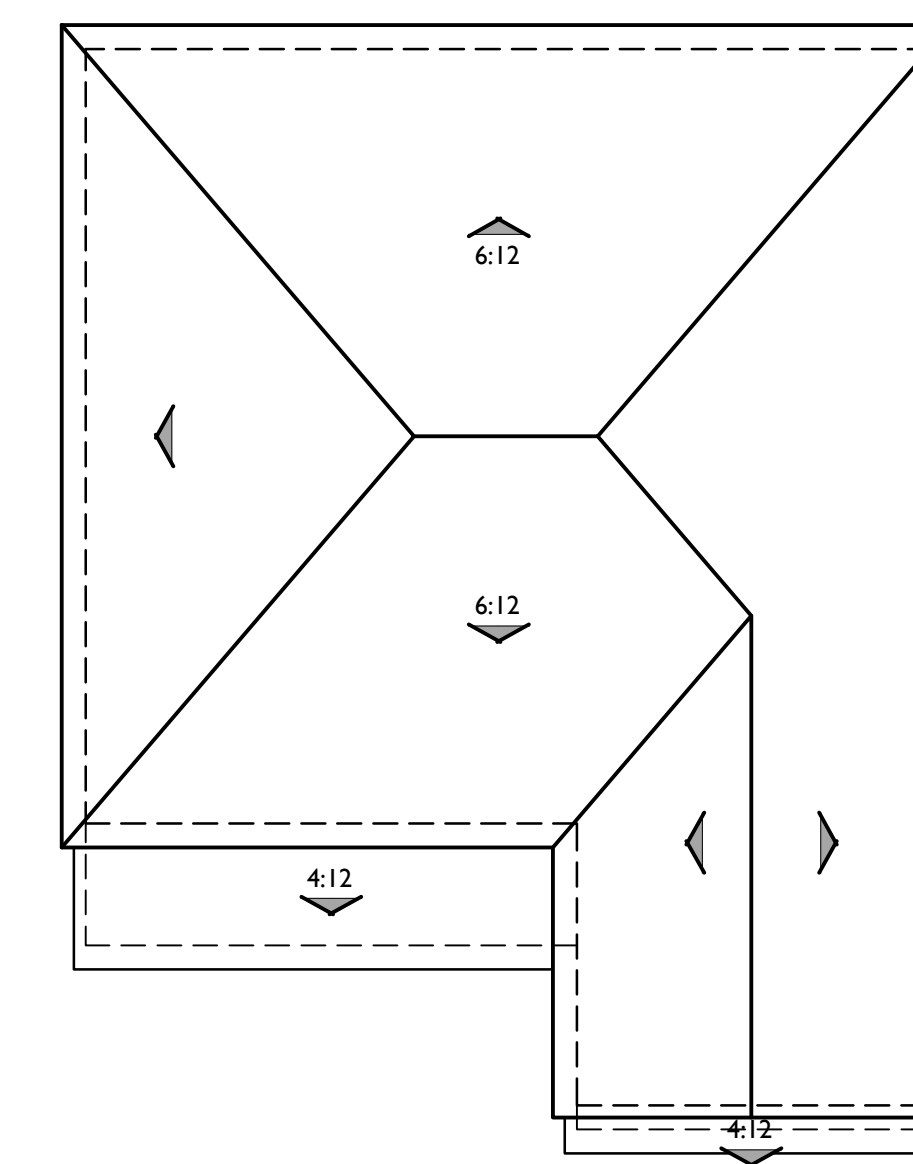

ROOF PLAN

B

PITCH: 7:12 U.N.O  
RAKE: 6"  
EAVE: 12"  
ROOF MATERIAL: CONCRETE FLAT TILE

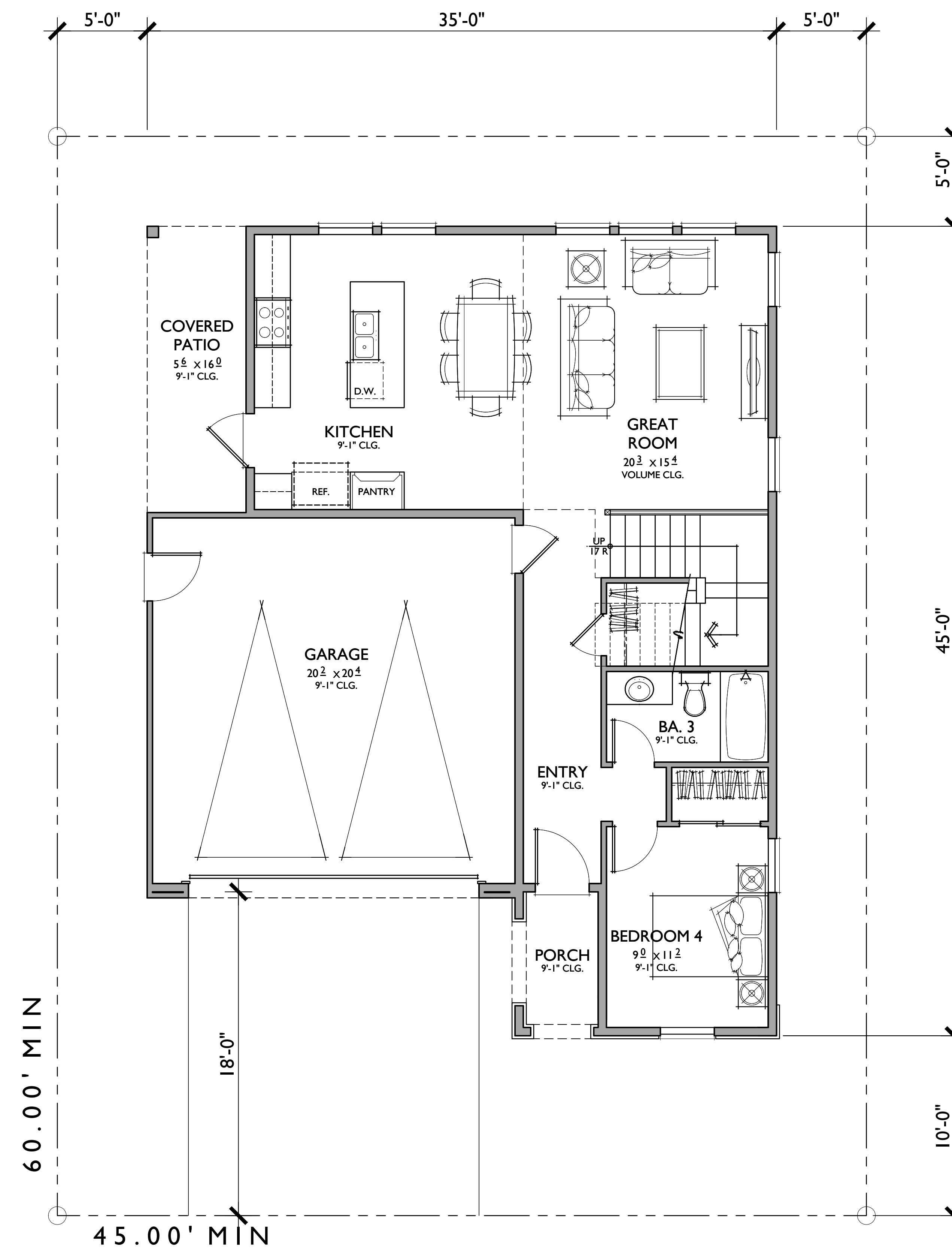
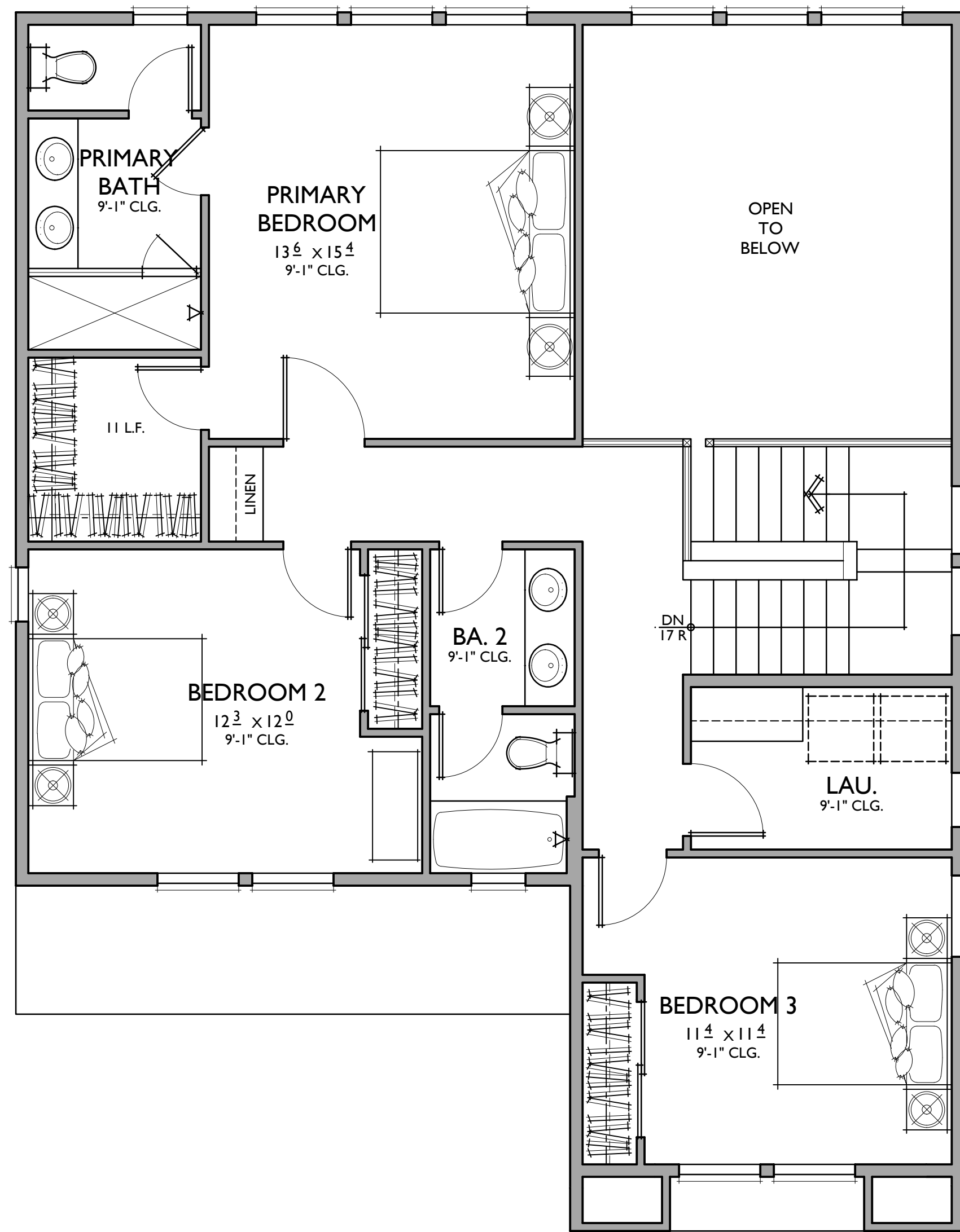

**PLAN 2**

4 BEDROOMS / 3 BATHS  
2 - CAR GARAGE

**FLOOR AREA TABLE**

1ST FLOOR	860 SQ. FT.
2ND FLOOR	975 SQ. FT.
<b>TOTAL LIVING</b>	<b>1835 SQ. FT.</b>
2 - CAR GARAGE	427 SQ. FT.
COVERED PATIO	88 SQ. FT.
PORCH	37 SQ. FT.

NOTE: SQUARE FOOTAGE MAY VARY DUE TO METHOD OF CALCULATION

05.21.24

**PLAN 2 C**

Reflects Tuscan Elevation

**LEUNG PROPERTY - PRODUCT 3**

Antioch, Ca

0 2 4 8 799.24099





REAR



FRONT

C- TUSCAN  
1/4"=1'-0"

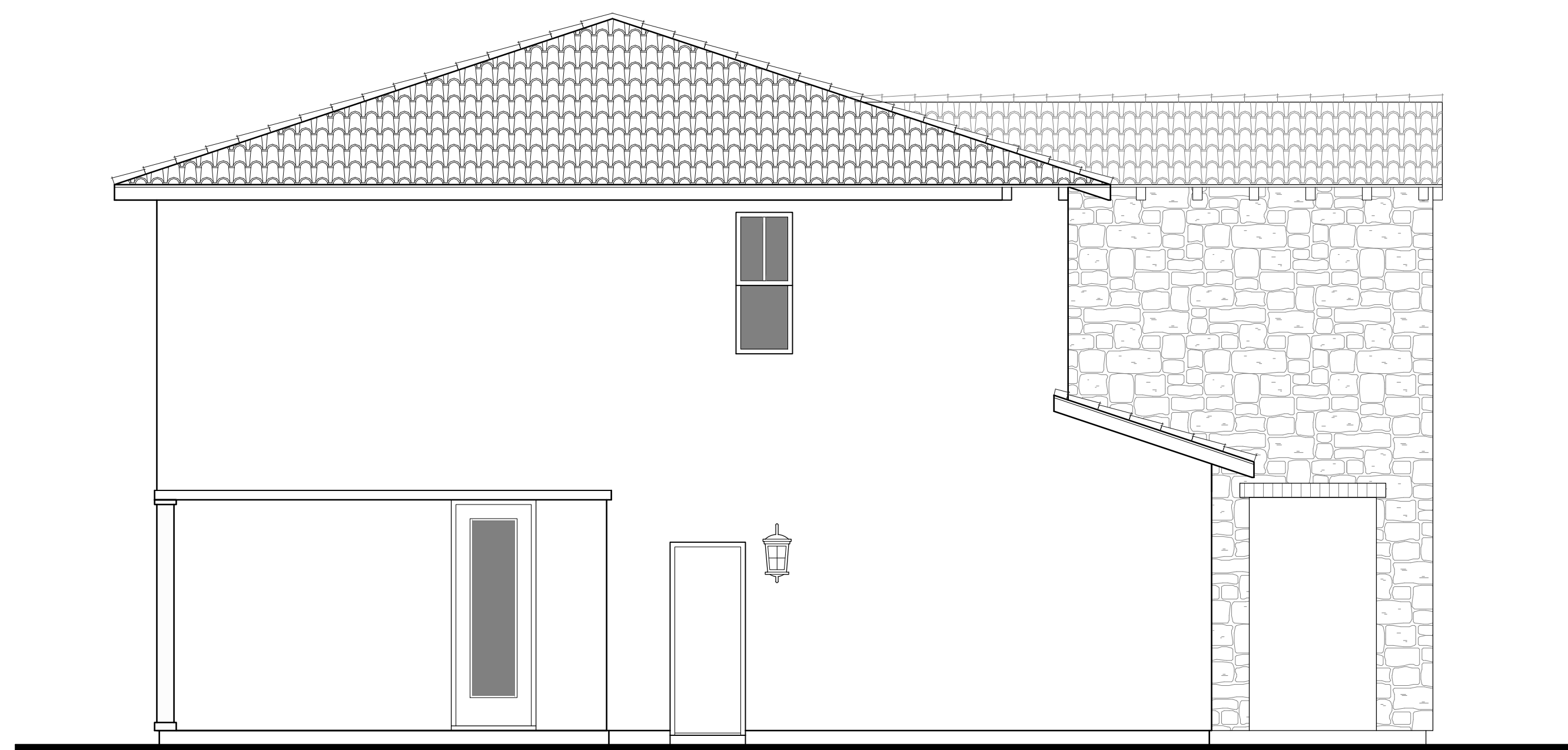

LEFT

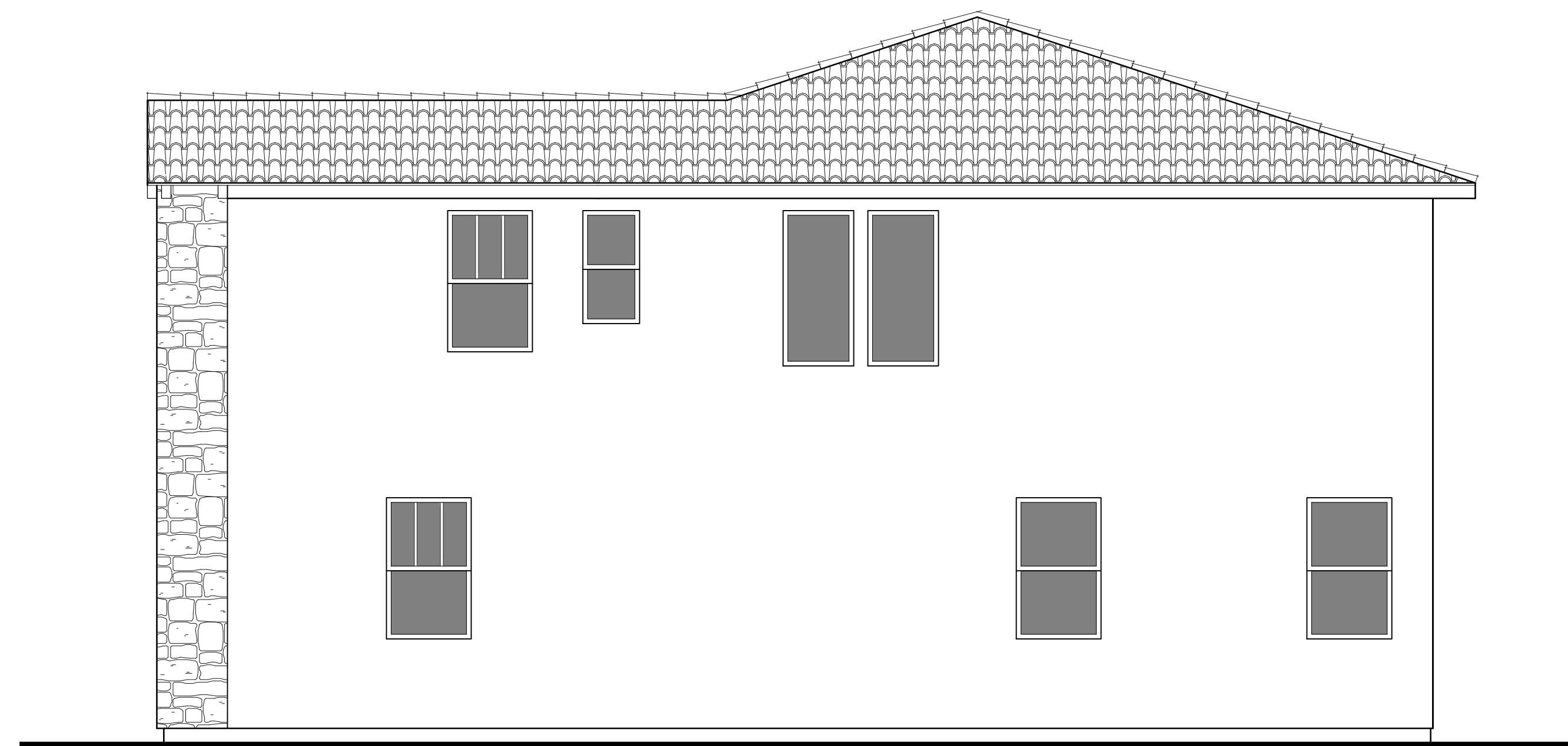

RIGHT

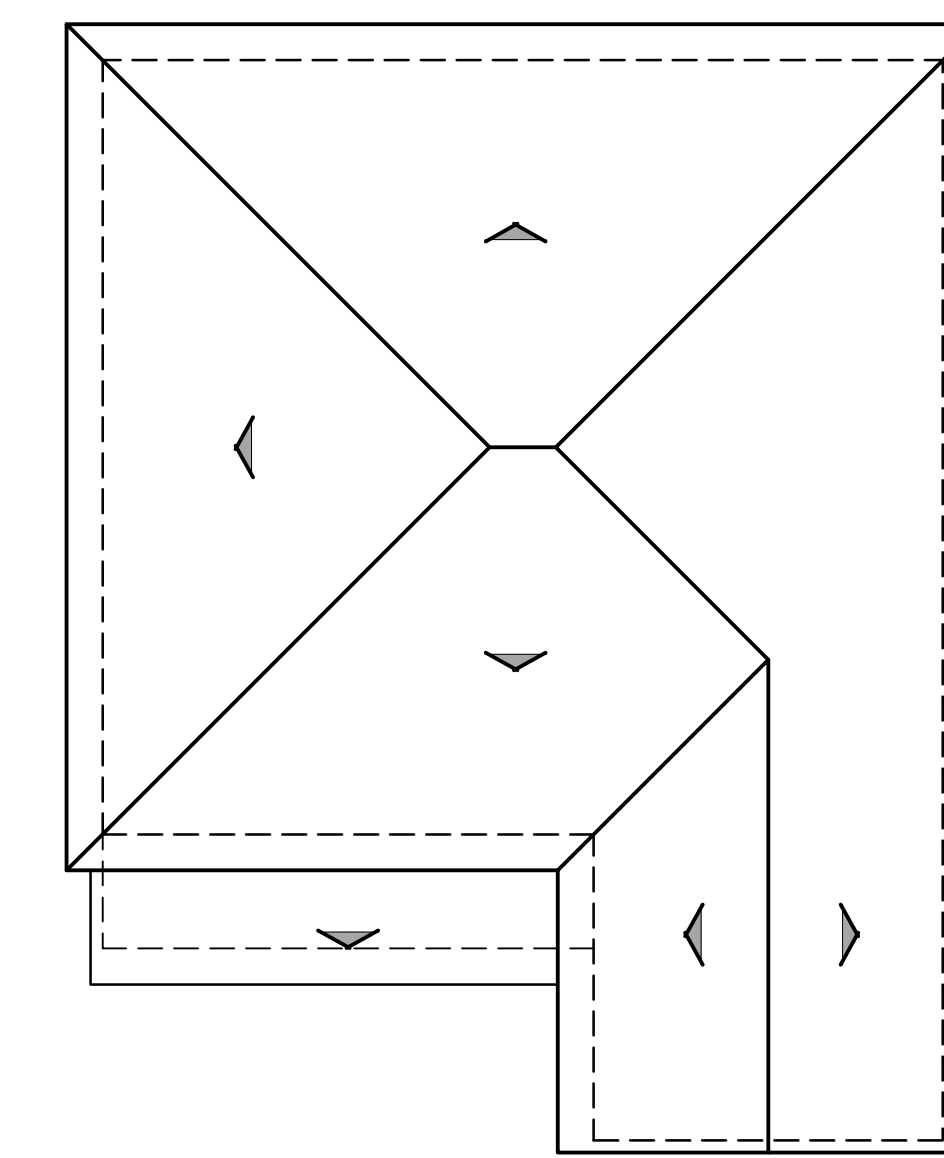

ROOF PLAN

C

PITCH: 4:12 U.N.O  
RAKE: 6"  
EAVE: 18"  
ROOF MATERIAL: CONCRETE 'S' TILE



SPANISH



FRENCH COUNTRY



TUSCAN

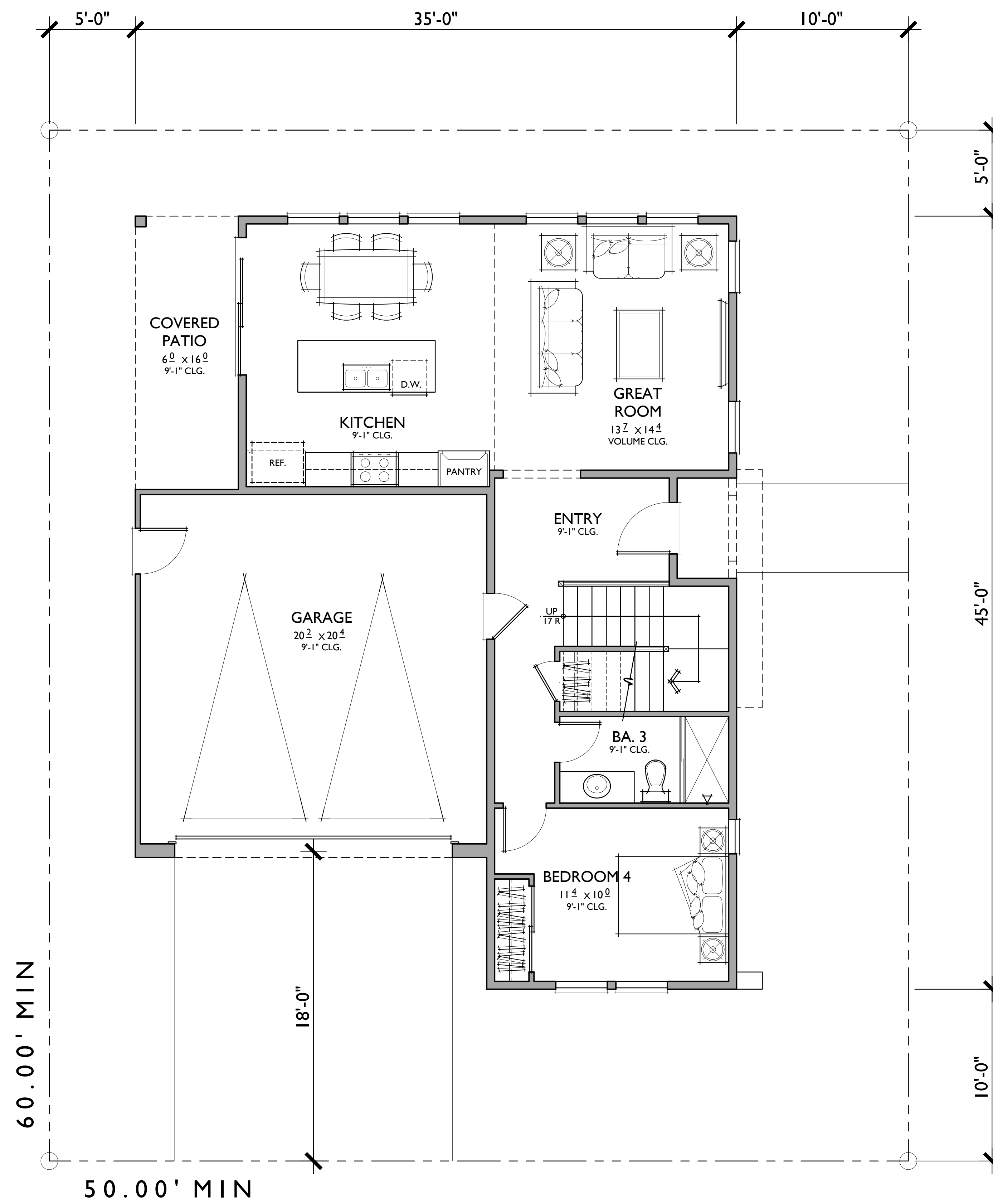
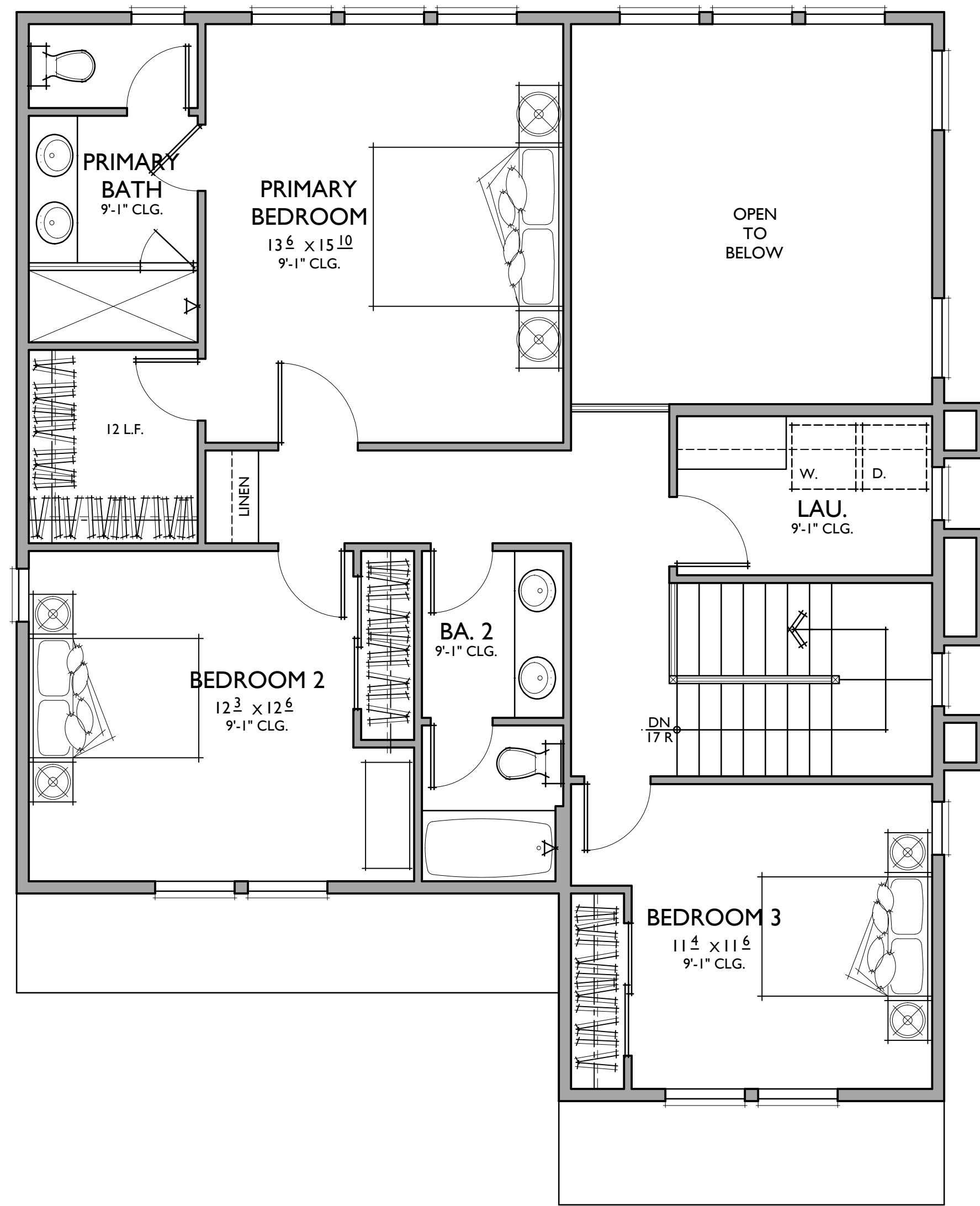

**PLAN 3**

4 BEDROOMS / 3 BATHS  
2 - CAR GARAGE

FLOOR AREA TABLE	
1ST FLOOR	869 SQ. FT.
2ND FLOOR	996 SQ. FT.
<b>TOTAL LIVING</b>	<b>1865 SQ. FT.</b>
2 - CAR GARAGE	427 SQ. FT.
COVERED PATIO	95 SQ. FT.
PORCH	20 SQ. FT.

NOTE: SQUARE FOOTAGE MAY VARY DUE TO METHOD OF CALCULATION

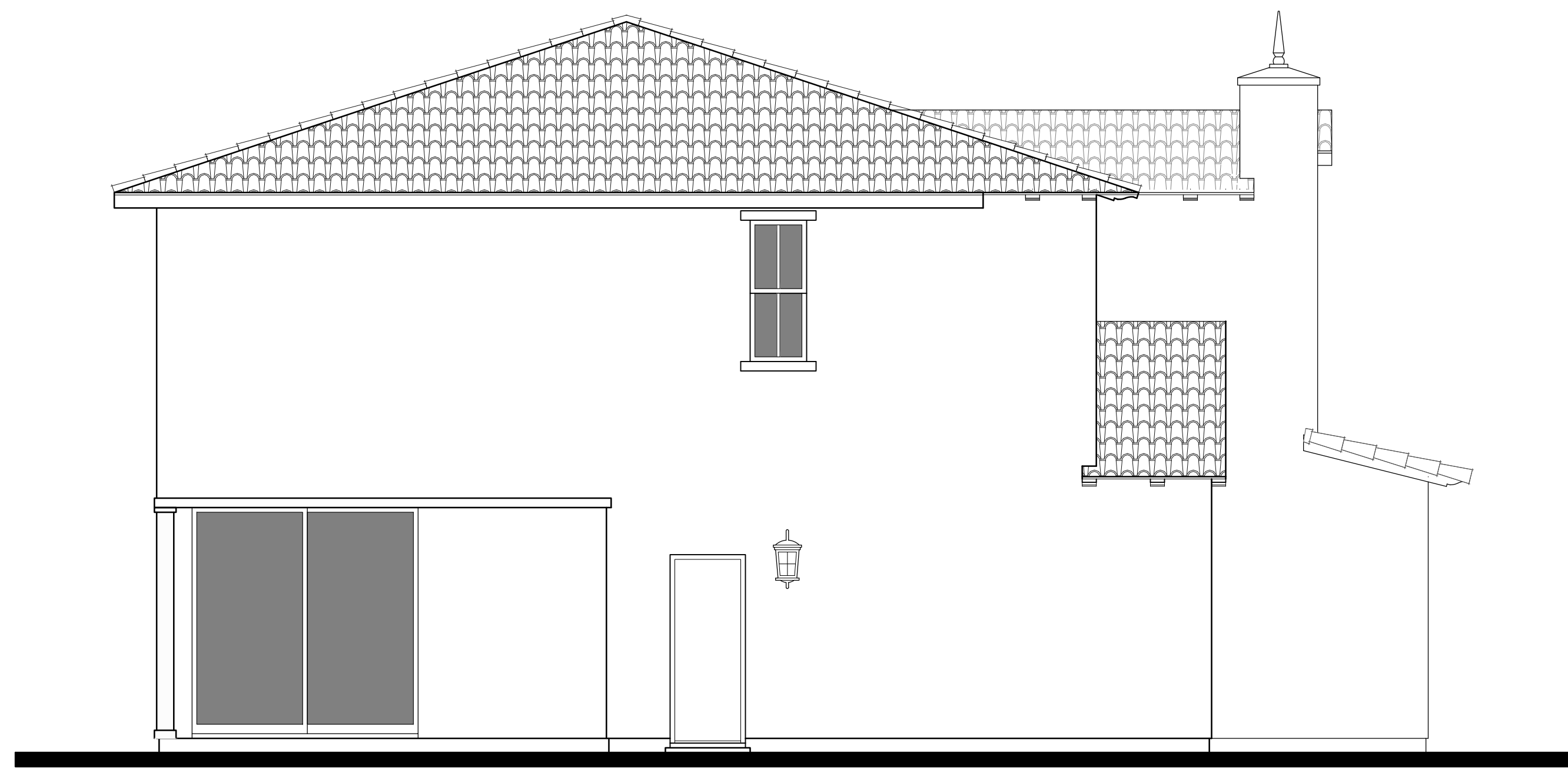

REAR



FRONT

A - SPANISH  
1/4"=1'-0"



LEFT



RIGHT

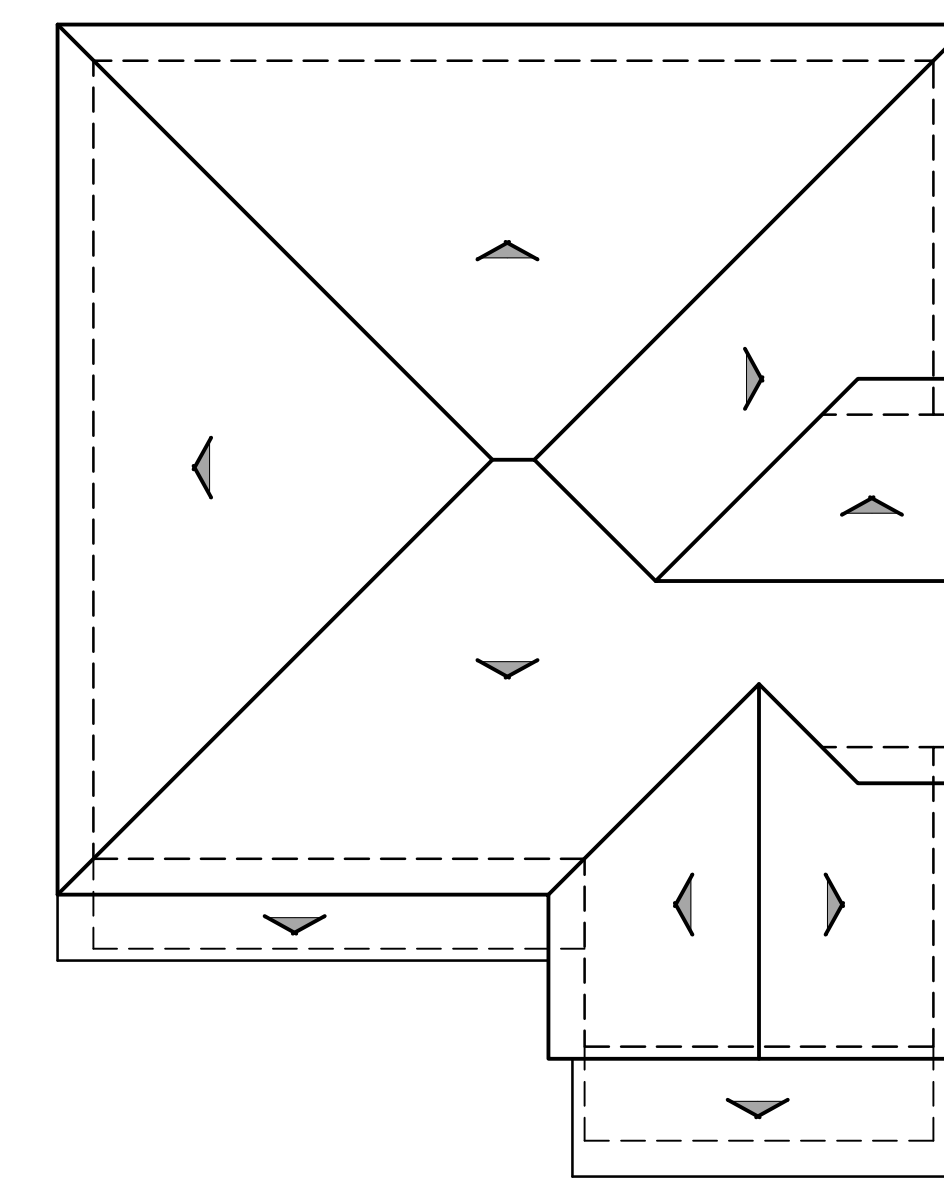

ROOF PLAN

A

PITCH: 3.5:12 U.N.O  
RAKE: 6"  
EAVE: 18"  
ROOF MATERIAL: CONCRETE S' TILE

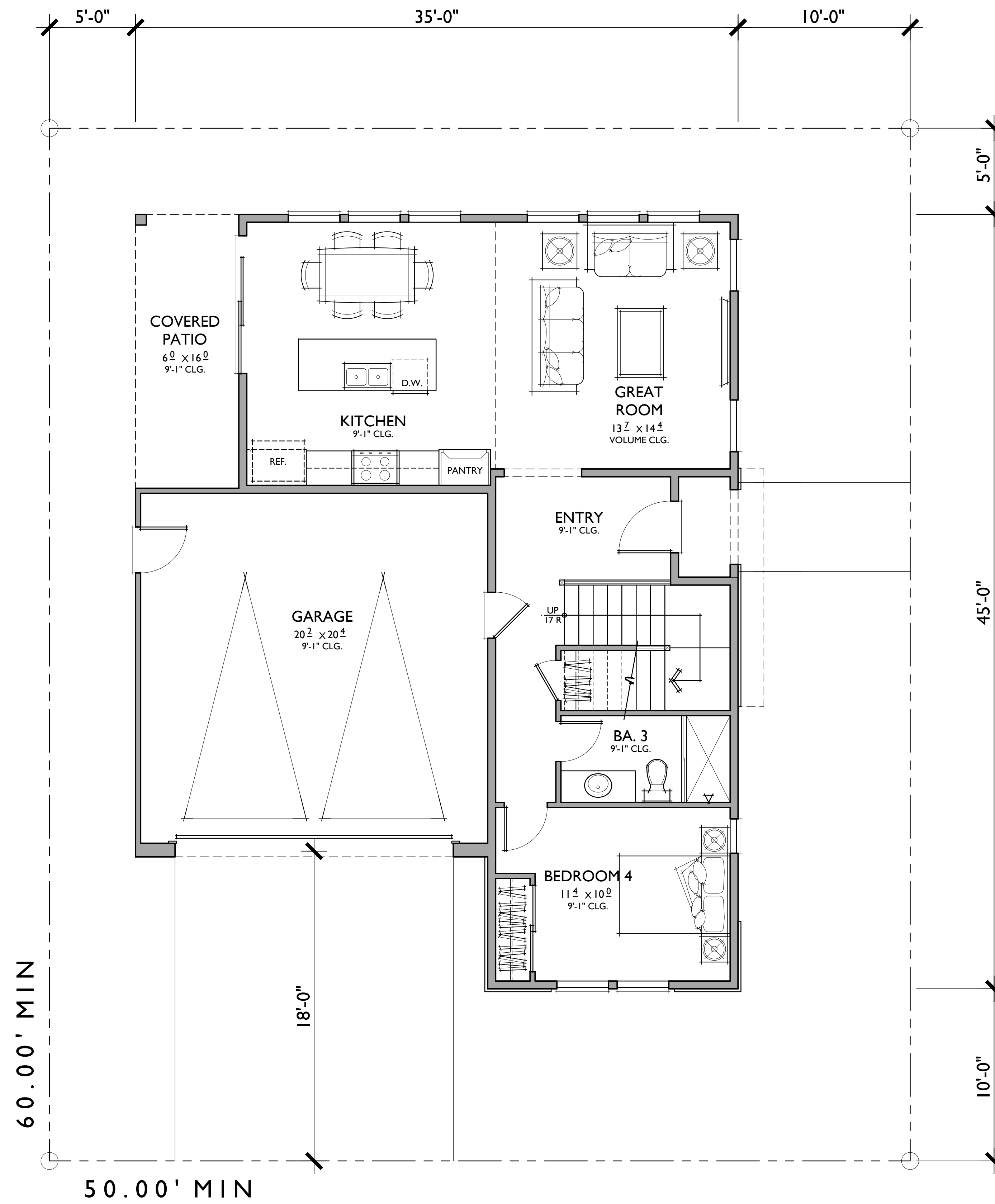

**PLAN 3**  
 4 BEDROOMS / 3 BATHS  
 2 - CAR GARAGE

FLOOR AREA TABLE	
1ST FLOOR	869 SQ. FT.
2ND FLOOR	996 SQ. FT.
<b>TOTAL LIVING</b>	<b>1865 SQ. FT.</b>
2 - CAR GARAGE	427 SQ. FT.
COVERED PATIO	95 SQ. FT.
PORCH	20 SQ. FT.

NOTE: SQUARE FOOTAGE MAY VARY DUE TO METHOD OF CALCULATION

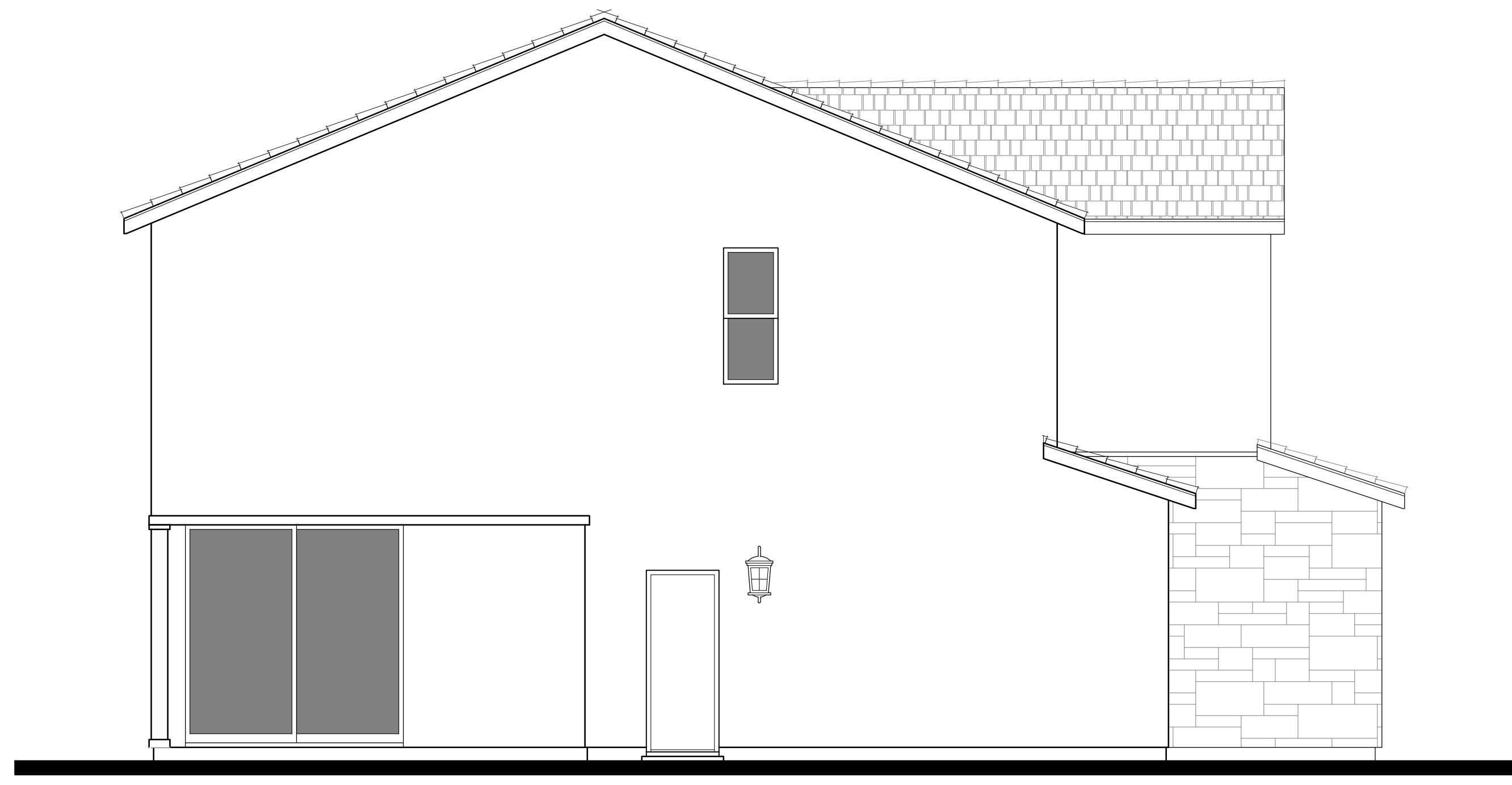

REAR



FRONT

B - FRENCH COUNTRY  
1/4"=1'-0"



LEFT

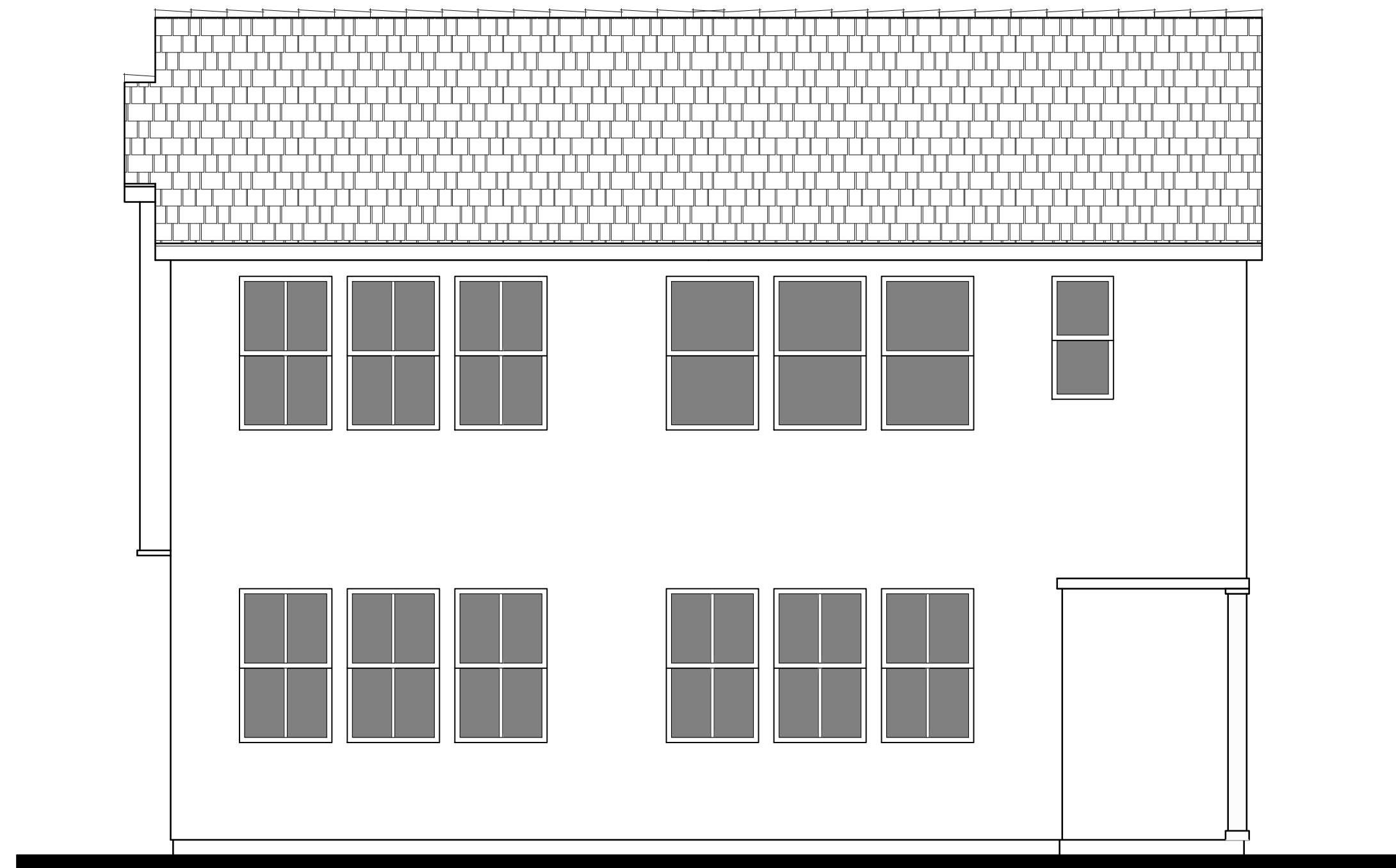

RIGHT

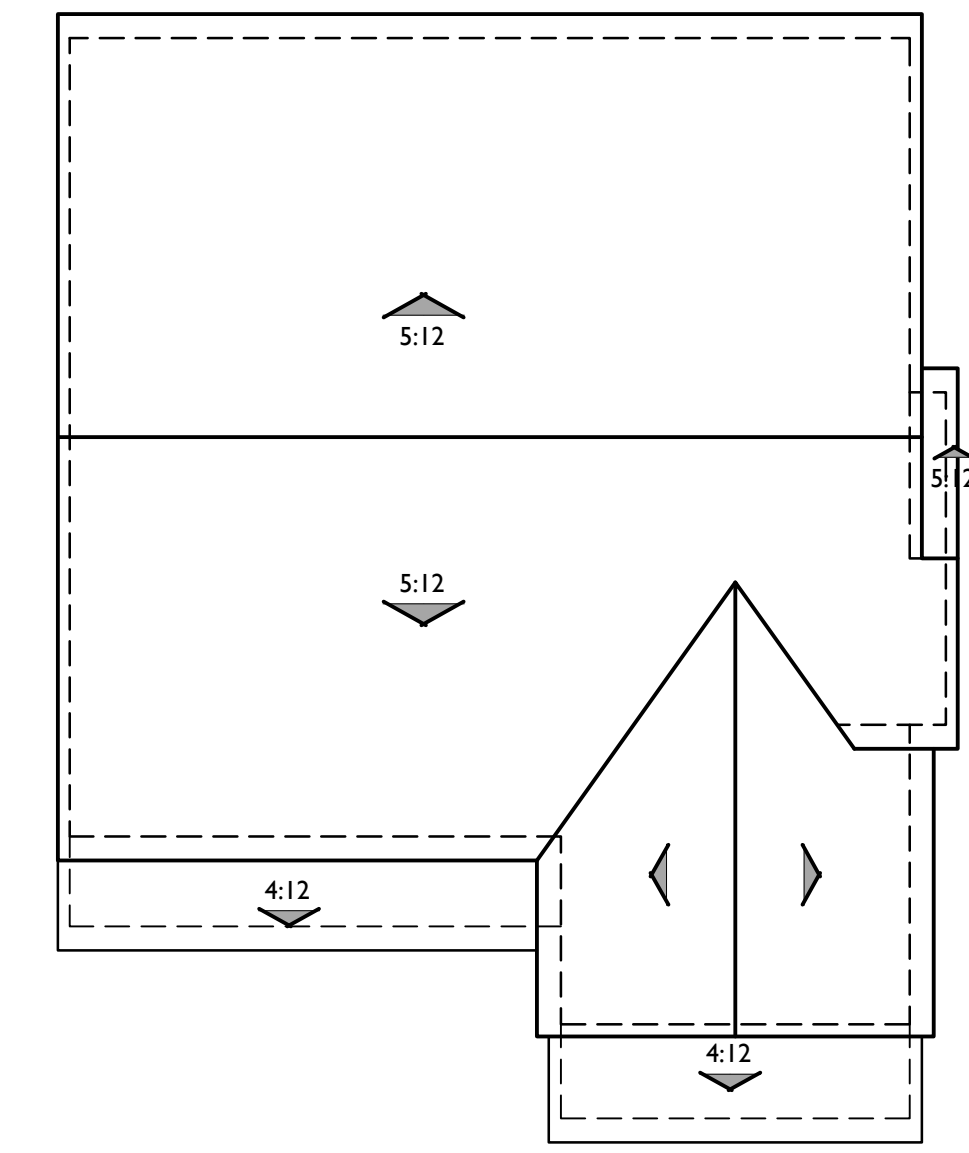

ROOF PLAN B  
1/8"=1'-0"  
PITCH: 7:12 U.N.O.  
RAKE: 6"  
EAVE: 12"  
ROOF MATERIAL: CONCRETE FLAT TILE

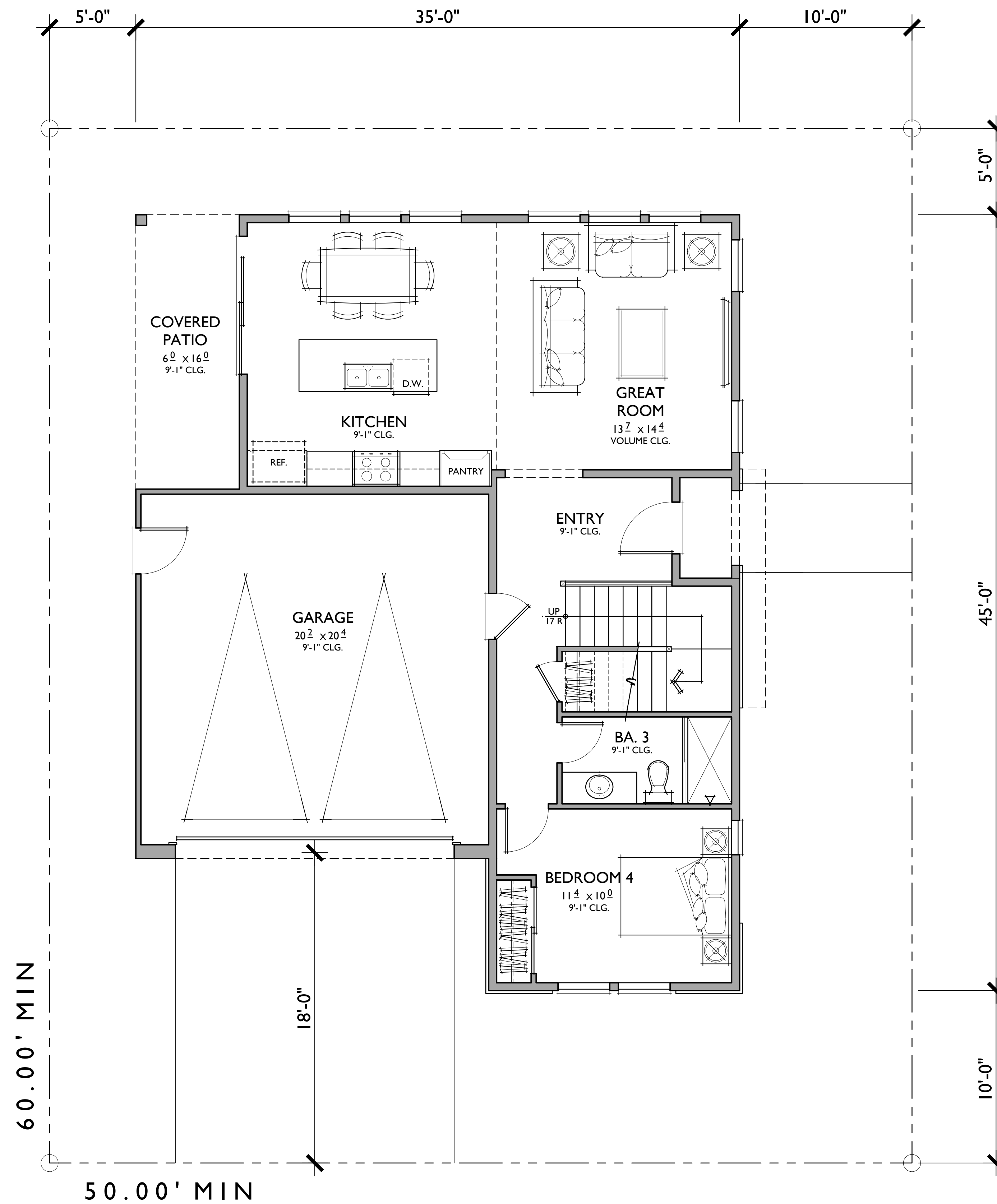
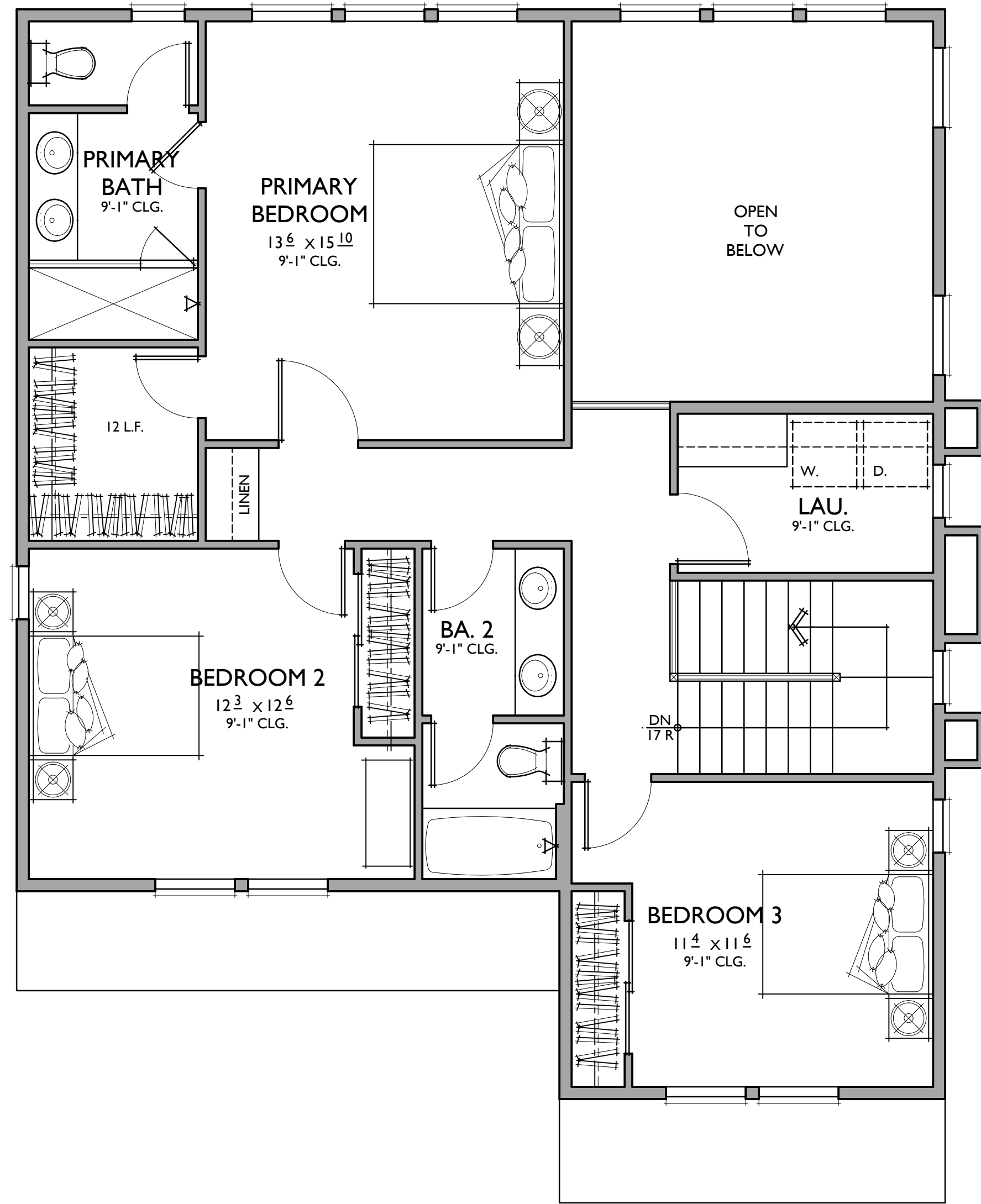

**PLAN 3**

4 BEDROOMS / 3 BATHS  
2 - CAR GARAGE

**FLOOR AREA TABLE**

1ST FLOOR	869 SQ. FT.
2ND FLOOR	996 SQ. FT.
<b>TOTAL LIVING</b>	<b>1865 SQ. FT.</b>
2 - CAR GARAGE	427 SQ. FT.
COVERED PATIO	95 SQ. FT.
PORCH	20 SQ. FT.

NOTE: SQUARE FOOTAGE MAY VARY DUE TO METHOD OF CALCULATION

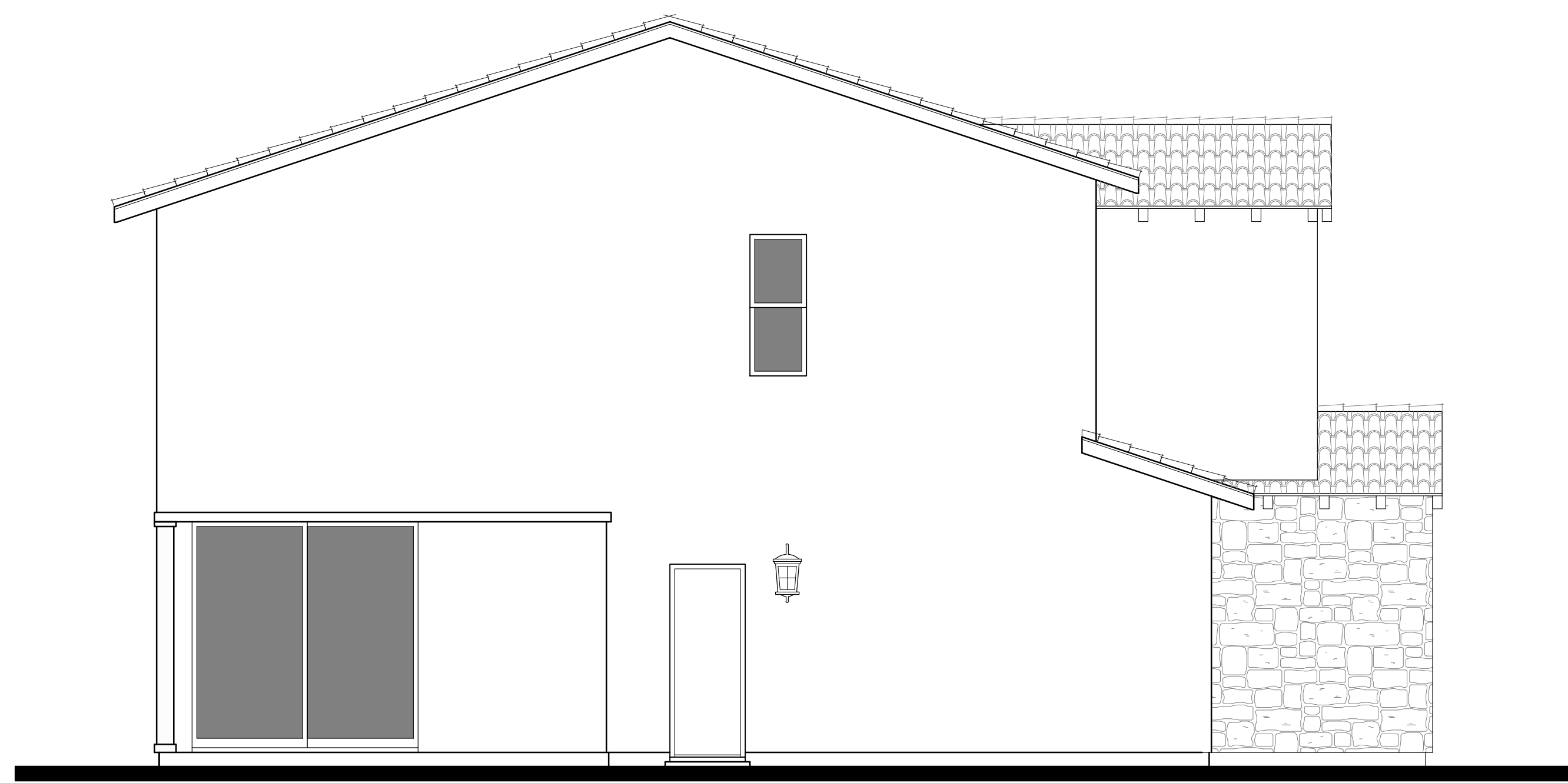

REAR



FRONT

C -TUSCAN  
1/4"=1'-0"



LEFT

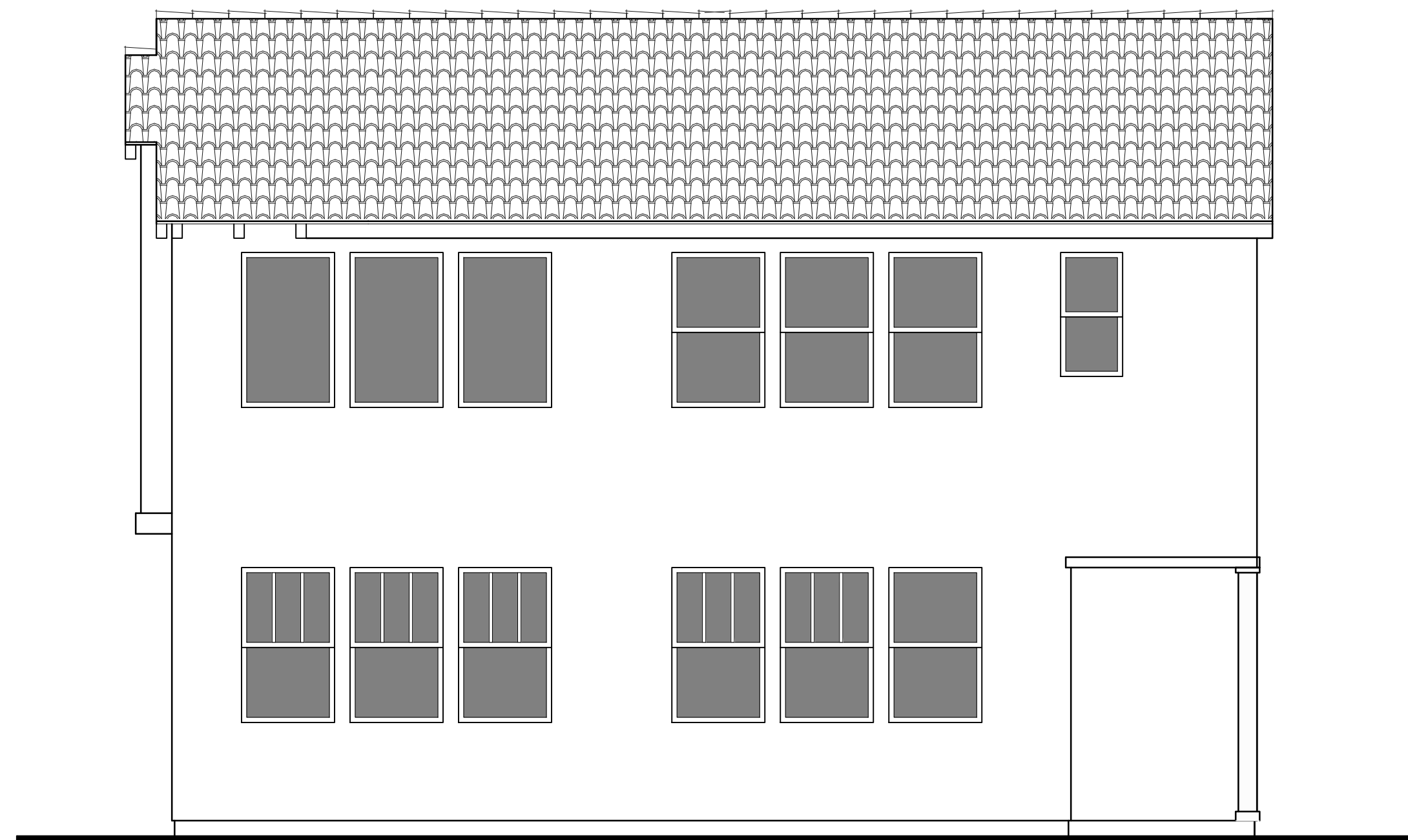

RIGHT

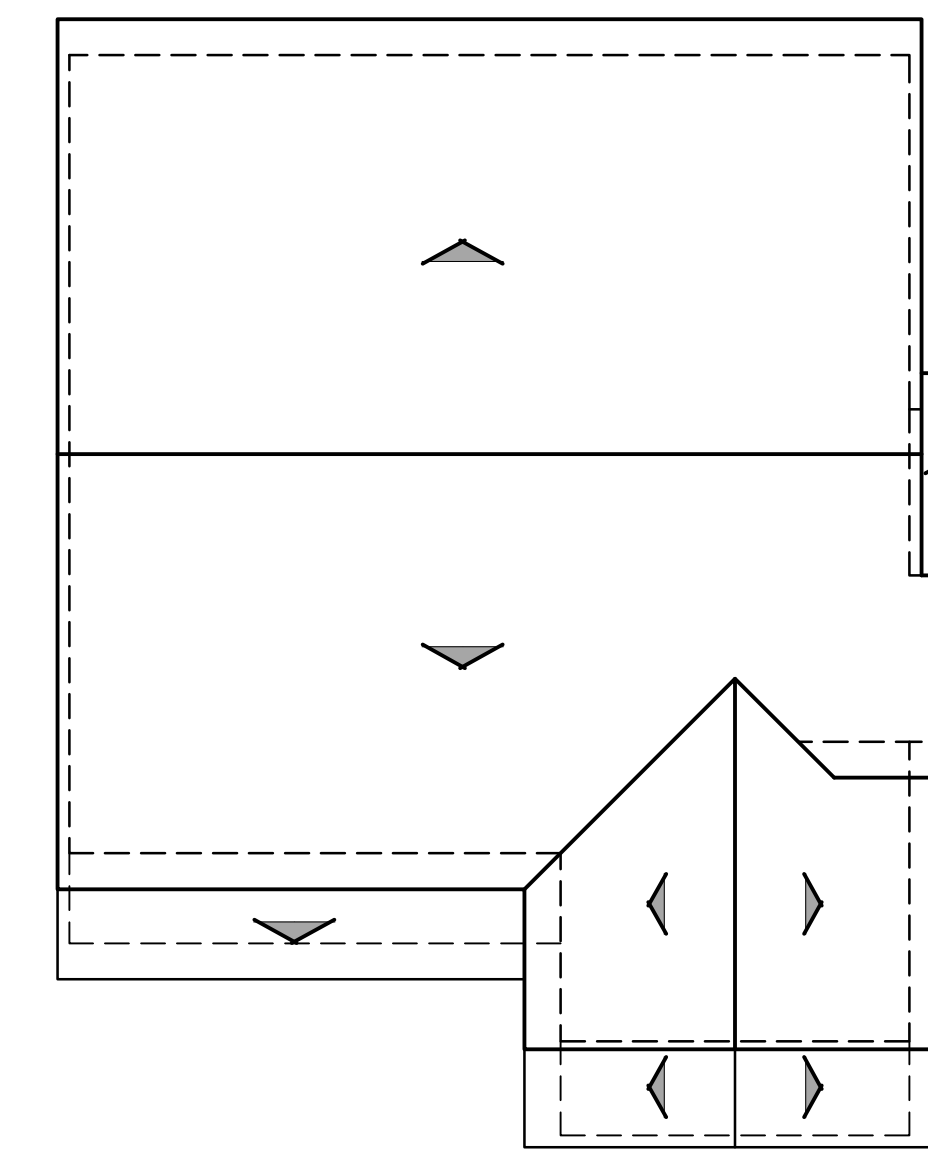

ROOF PLAN C

PITCH: 4:12 U.N.O  
RAKE: 6"  
EAVE: 18"  
ROOF MATERIAL: CONCRETE S' TILE





SPANISH



FRENCH COUNTRY



TUSCAN

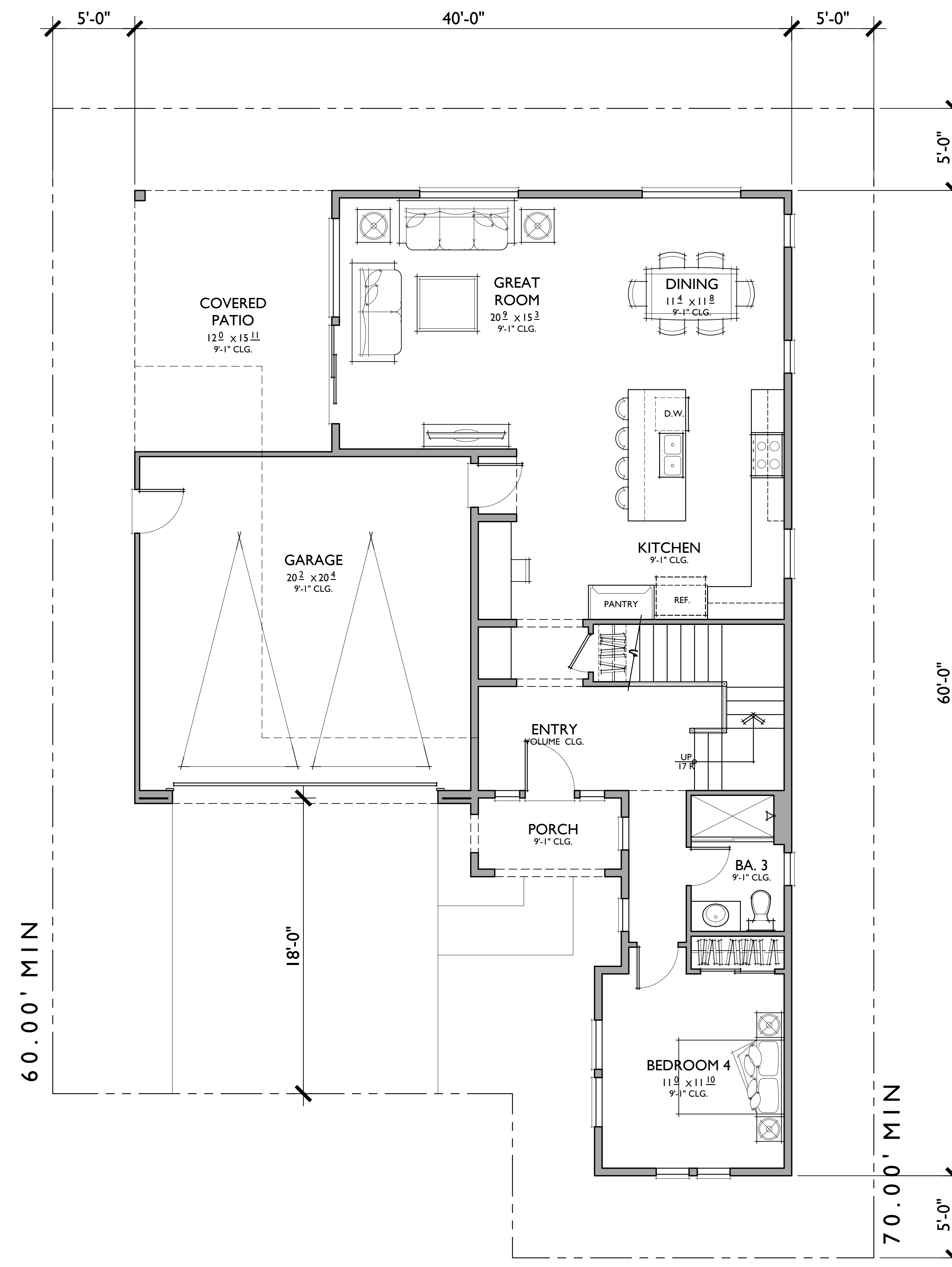
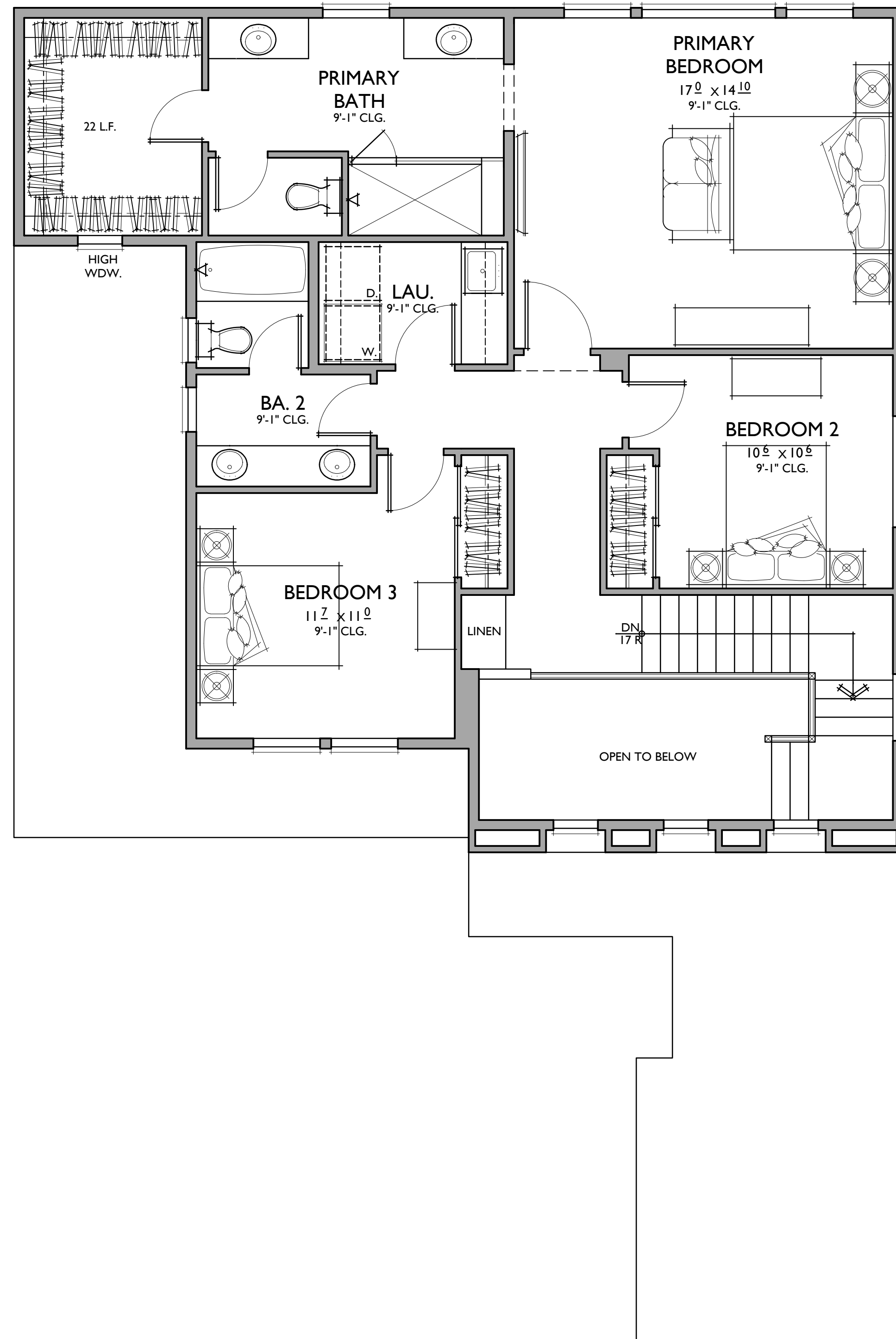

**PLAN 4**  
 4 BEDROOMS / 3 BATHS  
 2 - CAR GARAGE

FLOOR AREA TABLE	
1ST FLOOR	1,119 SQ. FT.
2ND FLOOR	1,054 SQ. FT.
<b>TOTAL LIVING</b>	<b>2173 SQ. FT.</b>
2 - CAR GARAGE	429 SQ. FT.
COVERED PATIO	191 SQ. FT.
PORCH	44 SQ. FT.

NOTE: SQUARE FOOTAGE MAY VARY DUE TO METHOD OF CALCULATION



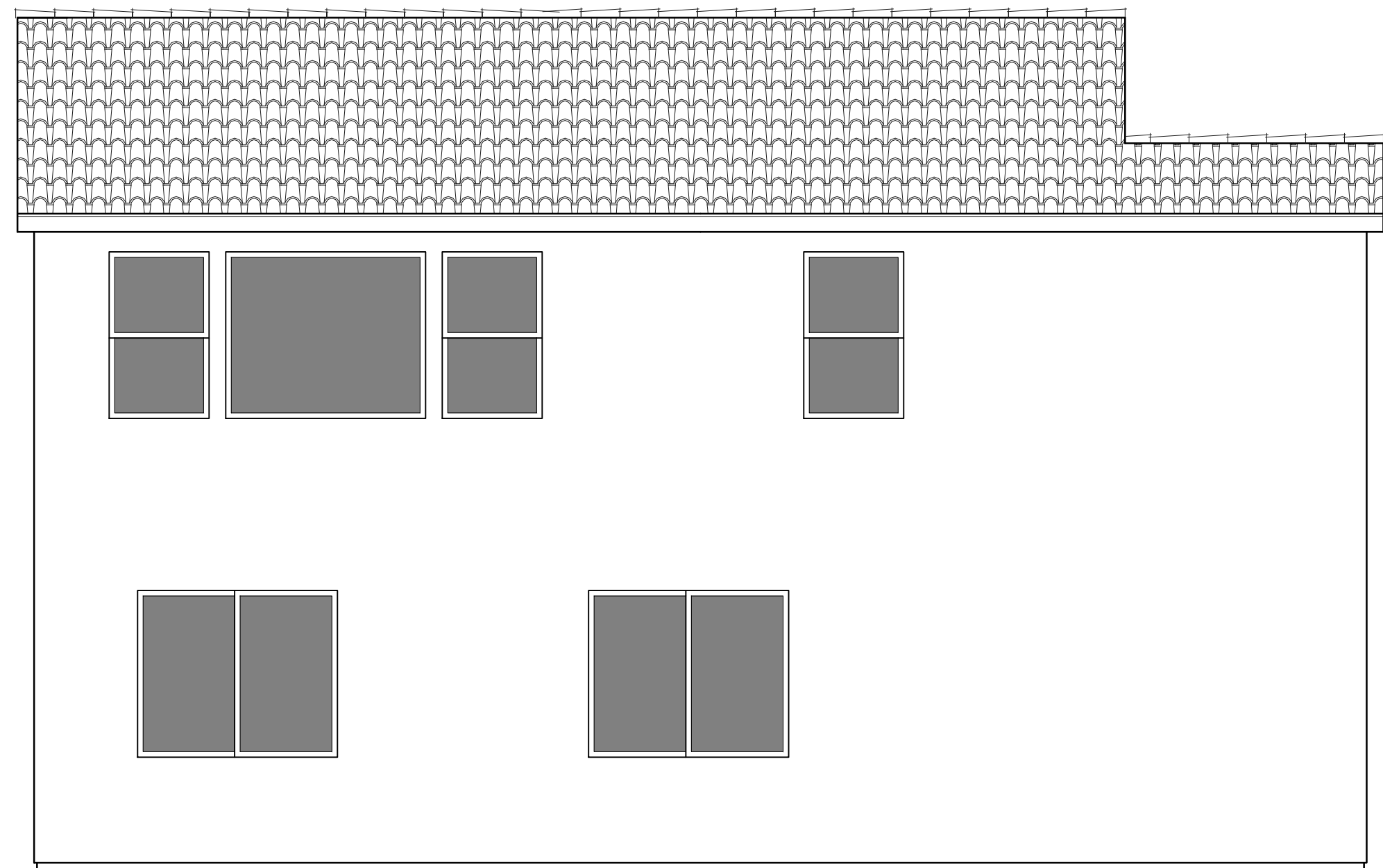

REAR



FRONT

A - SPANISH  
1/4"=1'-0"



LEFT

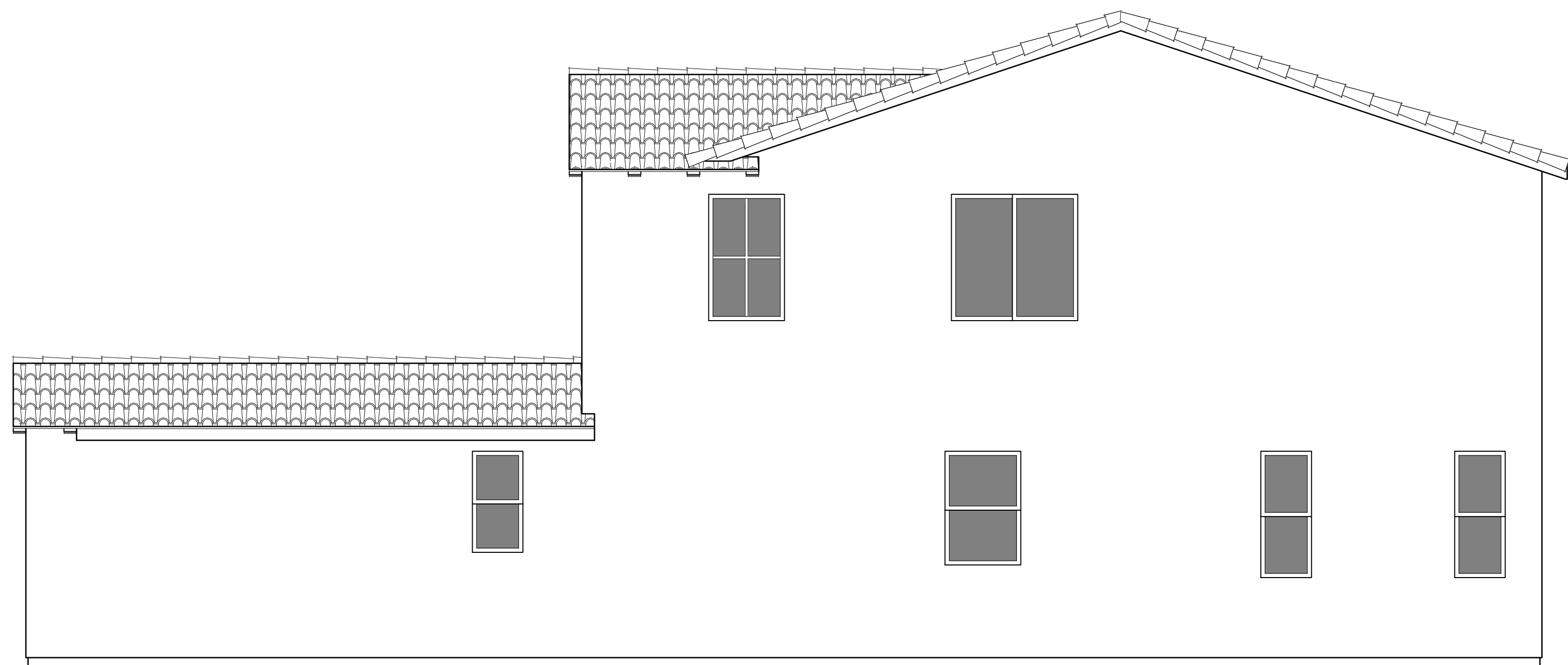

RIGHT

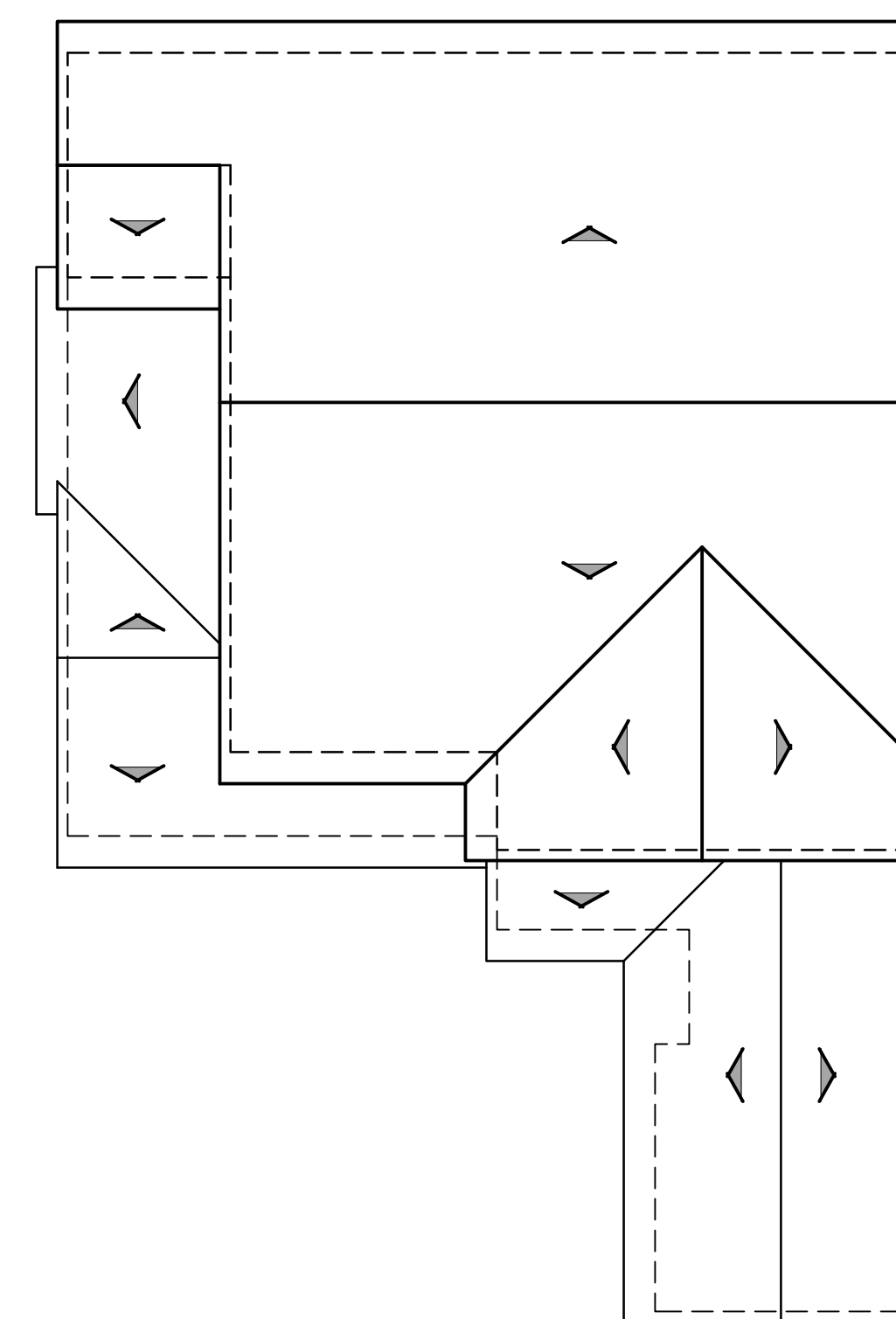

ROOF PLAN

A

PITCH: 3.5:12 U.N.O  
RAKE: 6"  
EAVE: 18"  
ROOF MATERIAL: CONCRETE 'S' TILE

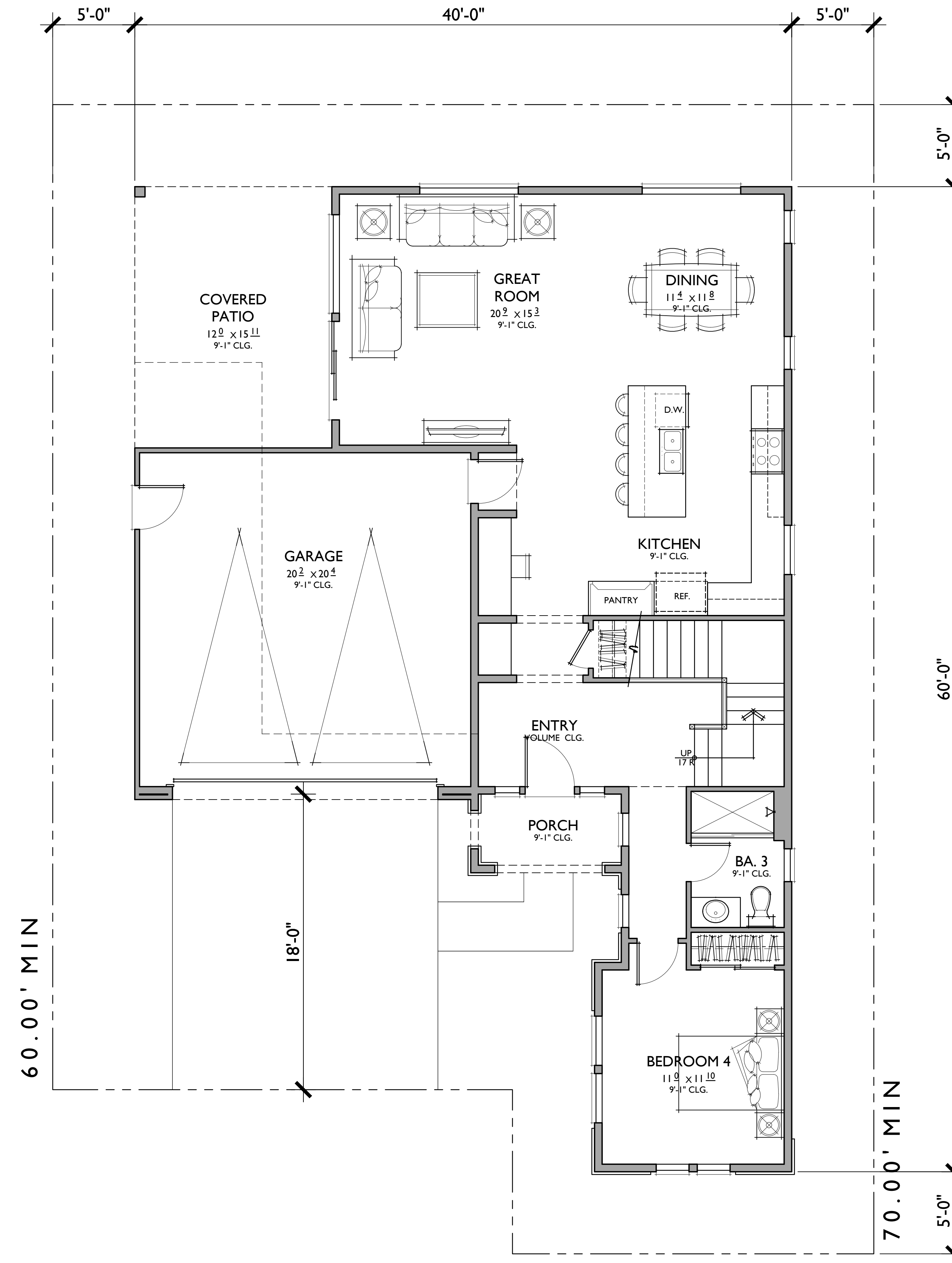
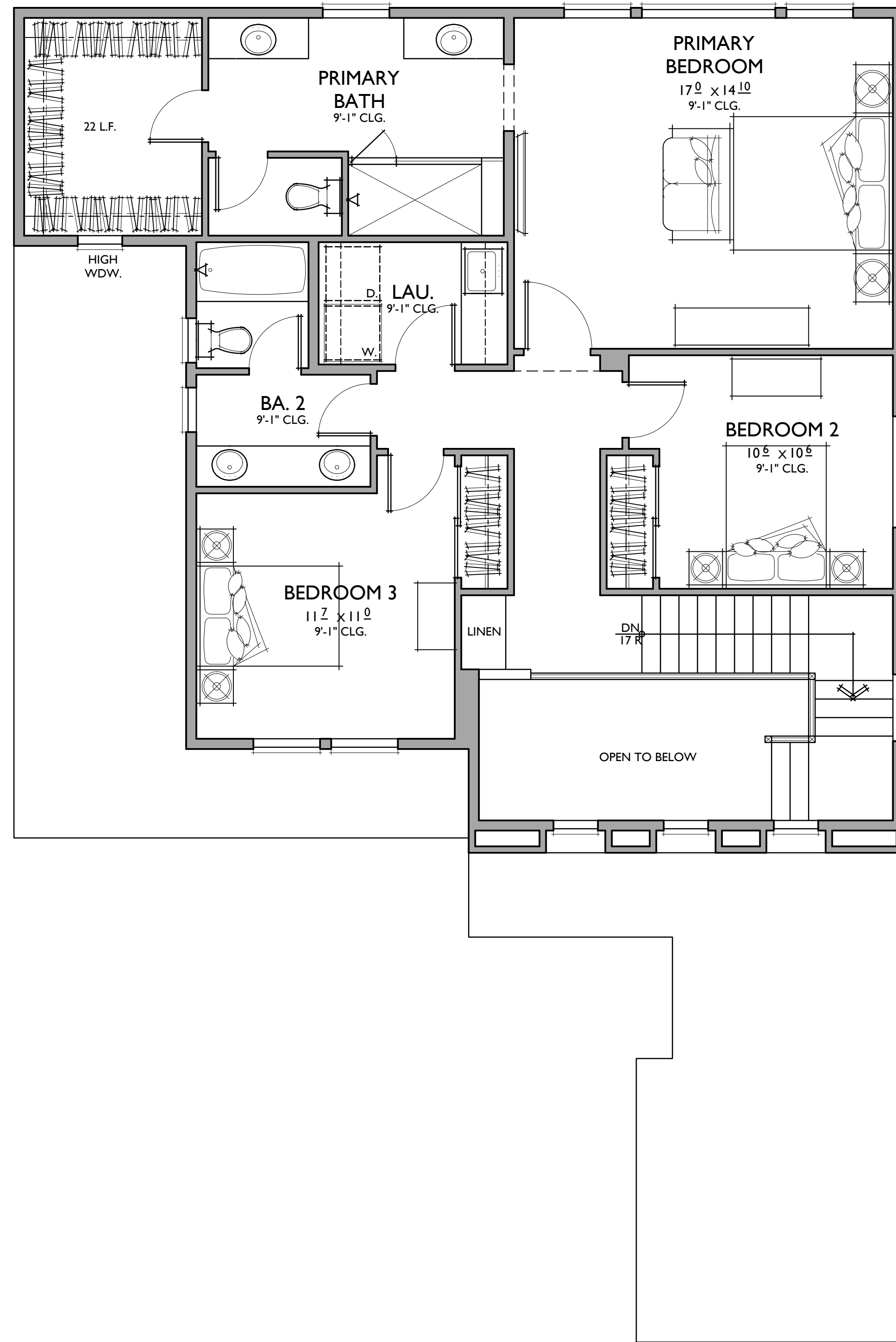

**PLAN 4**  
 4 BEDROOMS / 3 BATHS  
 2 - CAR GARAGE

FLOOR AREA TABLE	
1ST FLOOR	1,119 SQ. FT.
2ND FLOOR	1,054 SQ. FT.
<b>TOTAL LIVING</b>	<b>2173 SQ. FT.</b>
2 - CAR GARAGE	429 SQ. FT.
COVERED PATIO	191 SQ. FT.
PORCH	44 SQ. FT.

NOTE: SQUARE FOOTAGE MAY VARY DUE TO METHOD OF CALCULATION

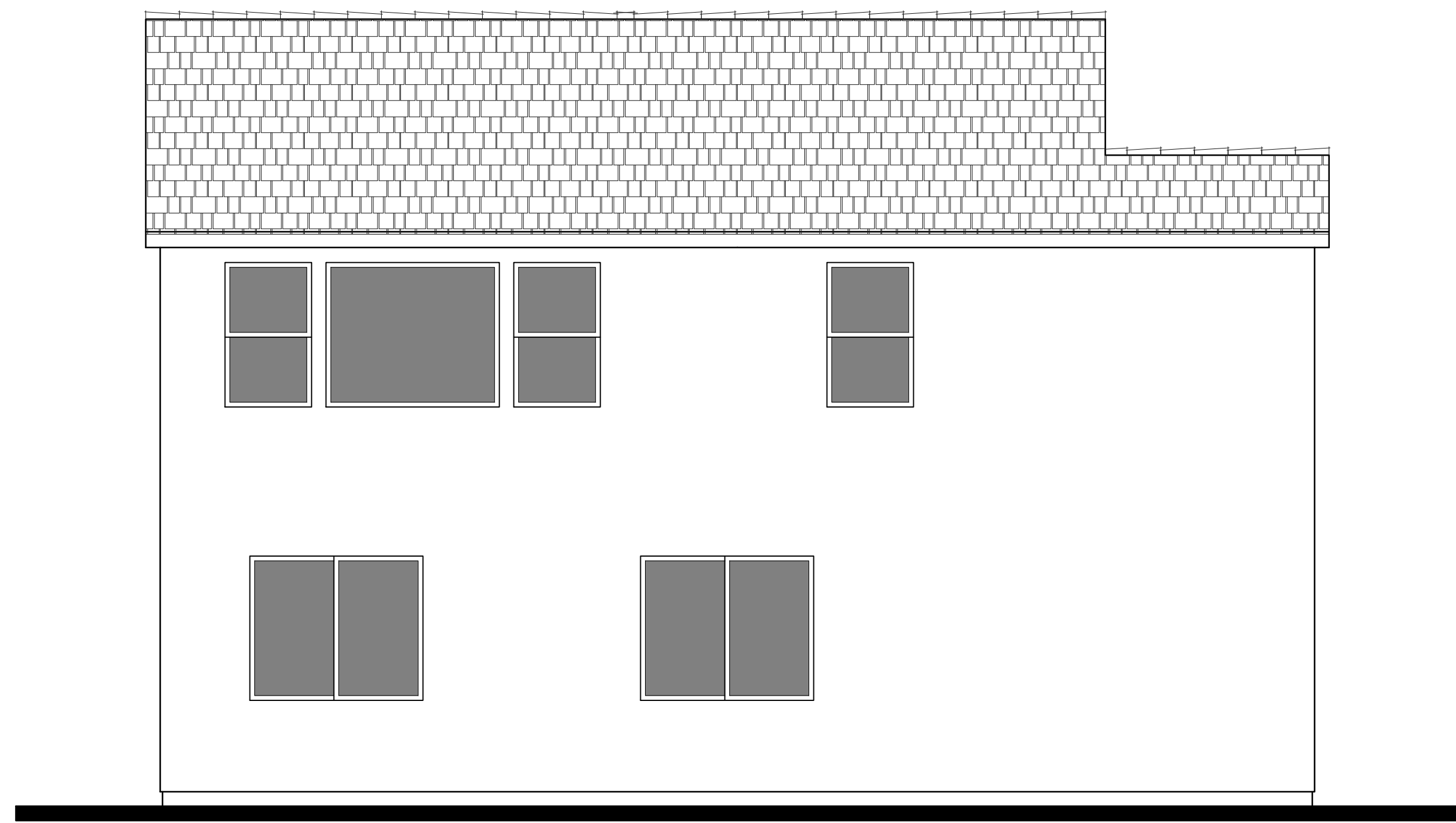

REAR



FRONT

B - FRENCH COUNTRY  
1/4"=1'-0"



LEFT

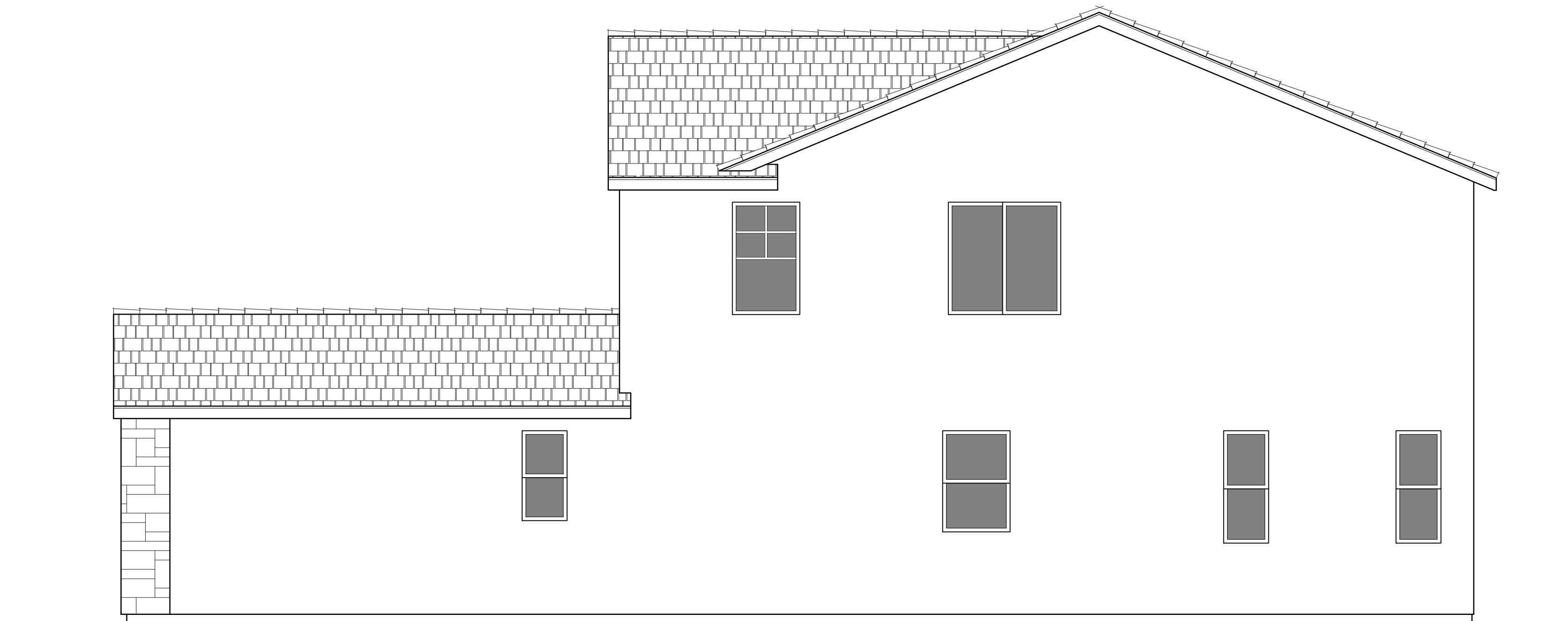

RIGHT

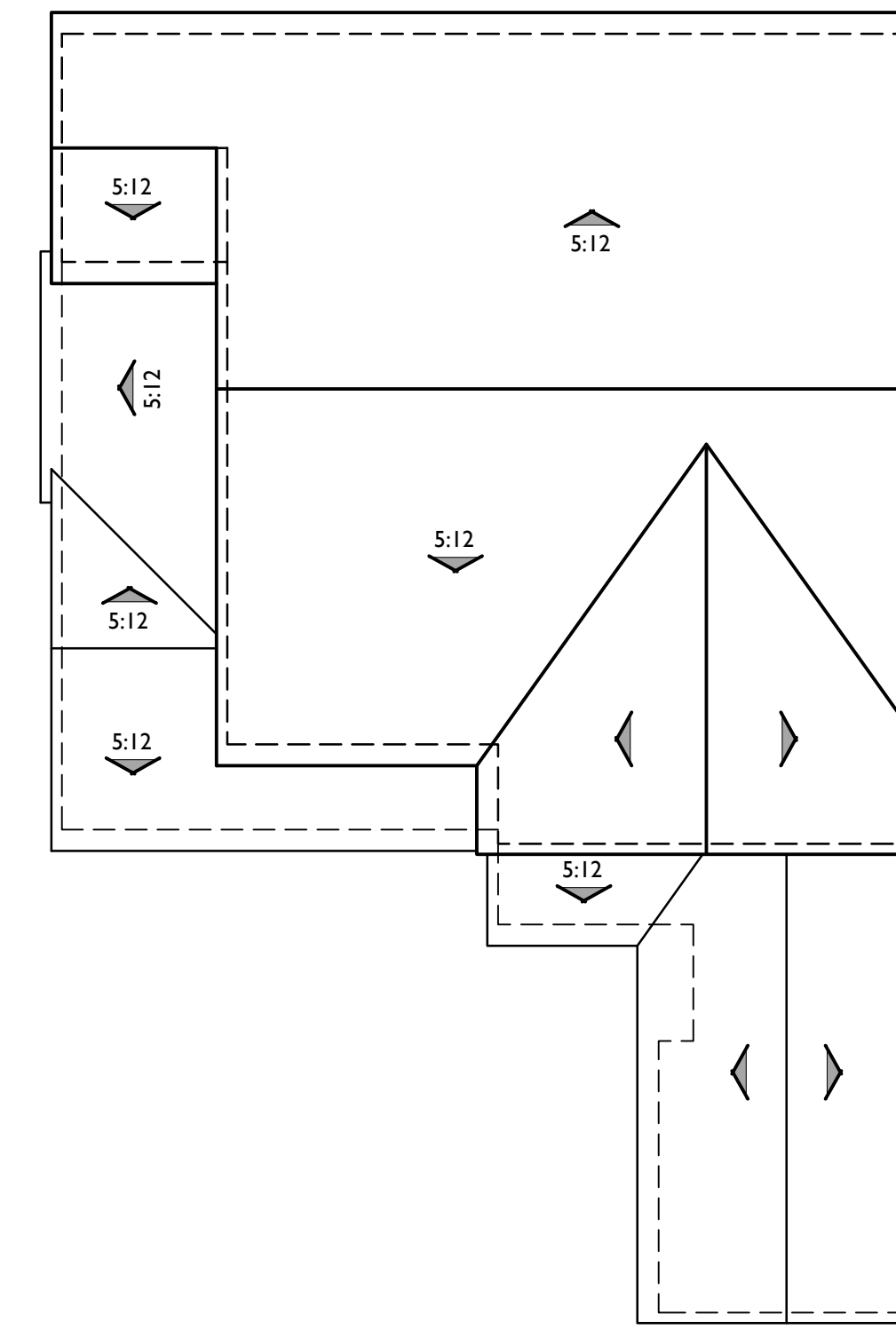

ROOF PLAN

B

PITCH: 7:12 U.N.O  
RAKE: 6"  
EAVE: 12"  
ROOF MATERIAL: CONCRETE FLAT TILE

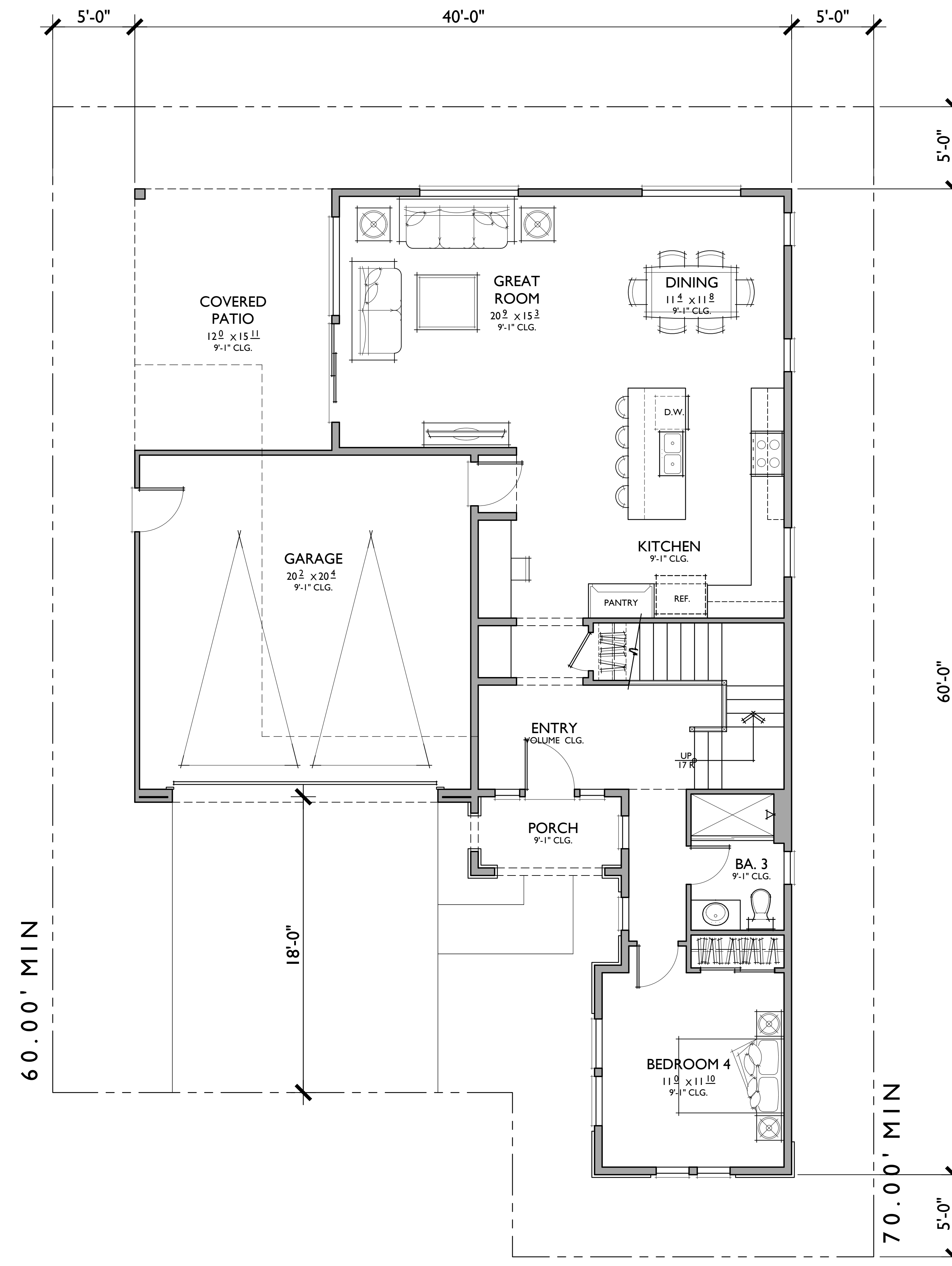
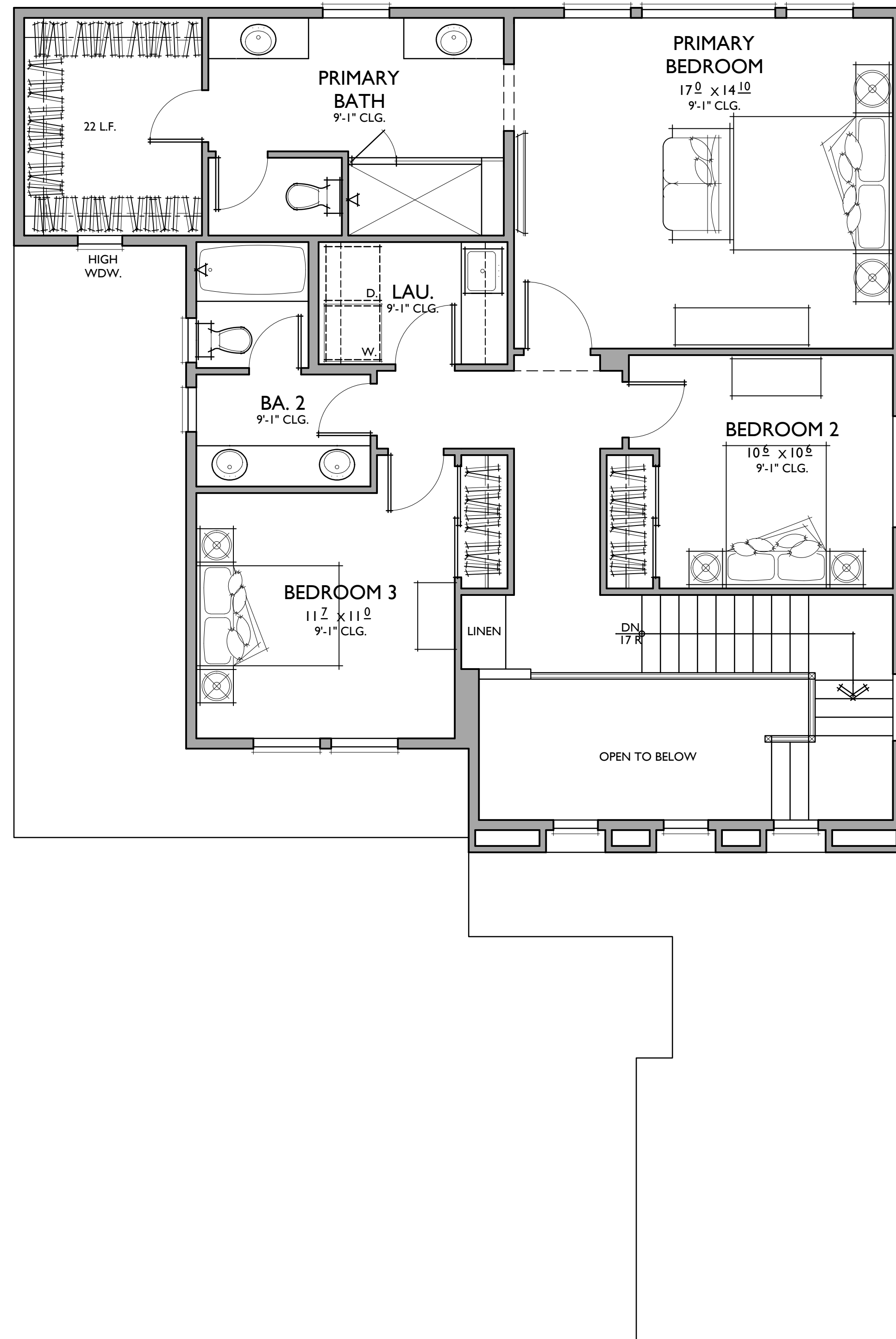

**PLAN 4**  
 4 BEDROOMS / 3 BATHS  
 2 - CAR GARAGE

FLOOR AREA TABLE	
1ST FLOOR	1,119 SQ. FT.
2ND FLOOR	1,054 SQ. FT.
<b>TOTAL LIVING</b>	<b>2173 SQ. FT.</b>
2 - CAR GARAGE	429 SQ. FT.
COVERED PATIO	191 SQ. FT.
PORCH	44 SQ. FT.

NOTE: SQUARE FOOTAGE MAY VARY DUE TO METHOD OF CALCULATION

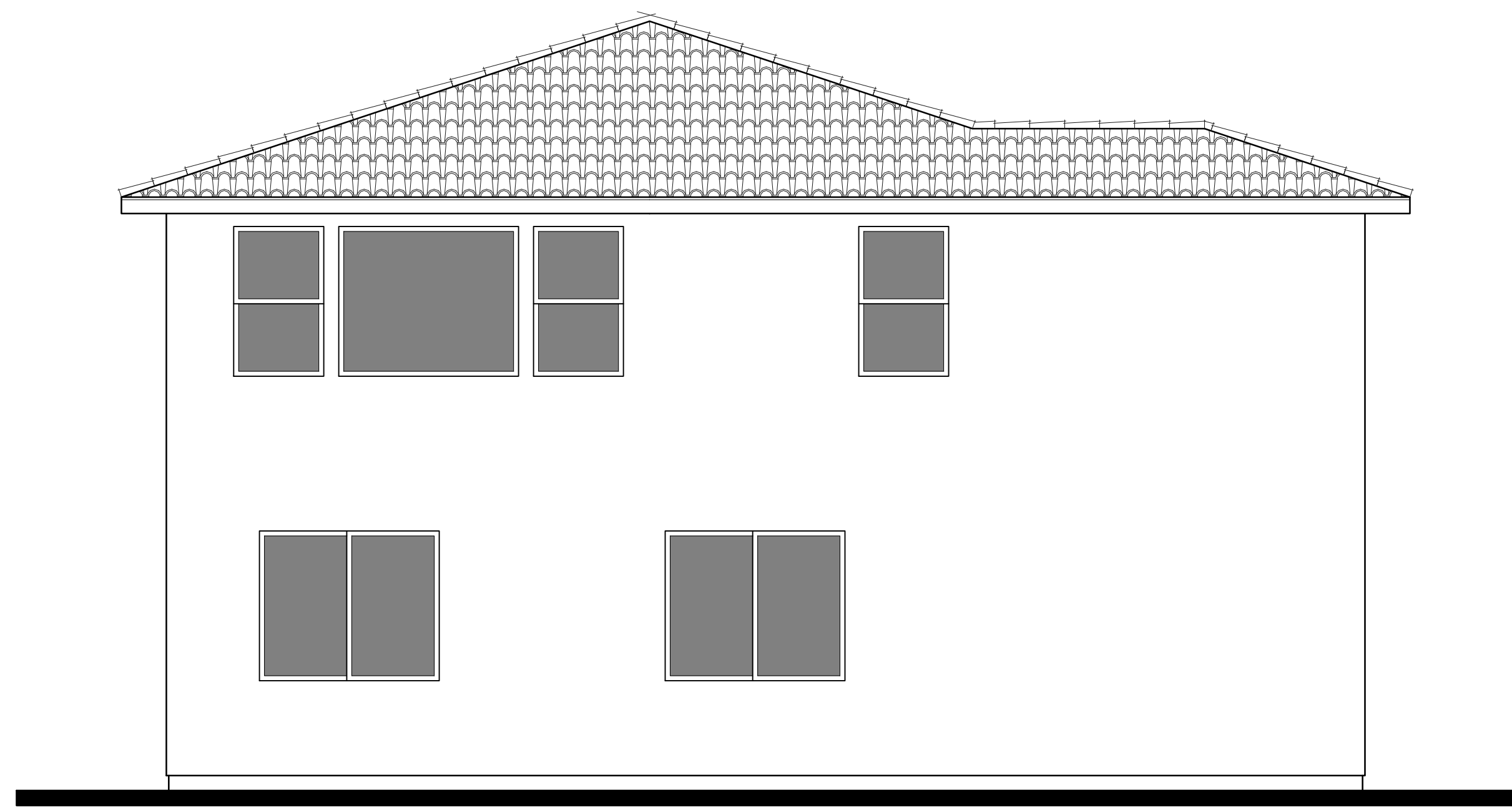

REAR



FRONT

C - TUSCAN  
1/4"=1'-0"



LEFT

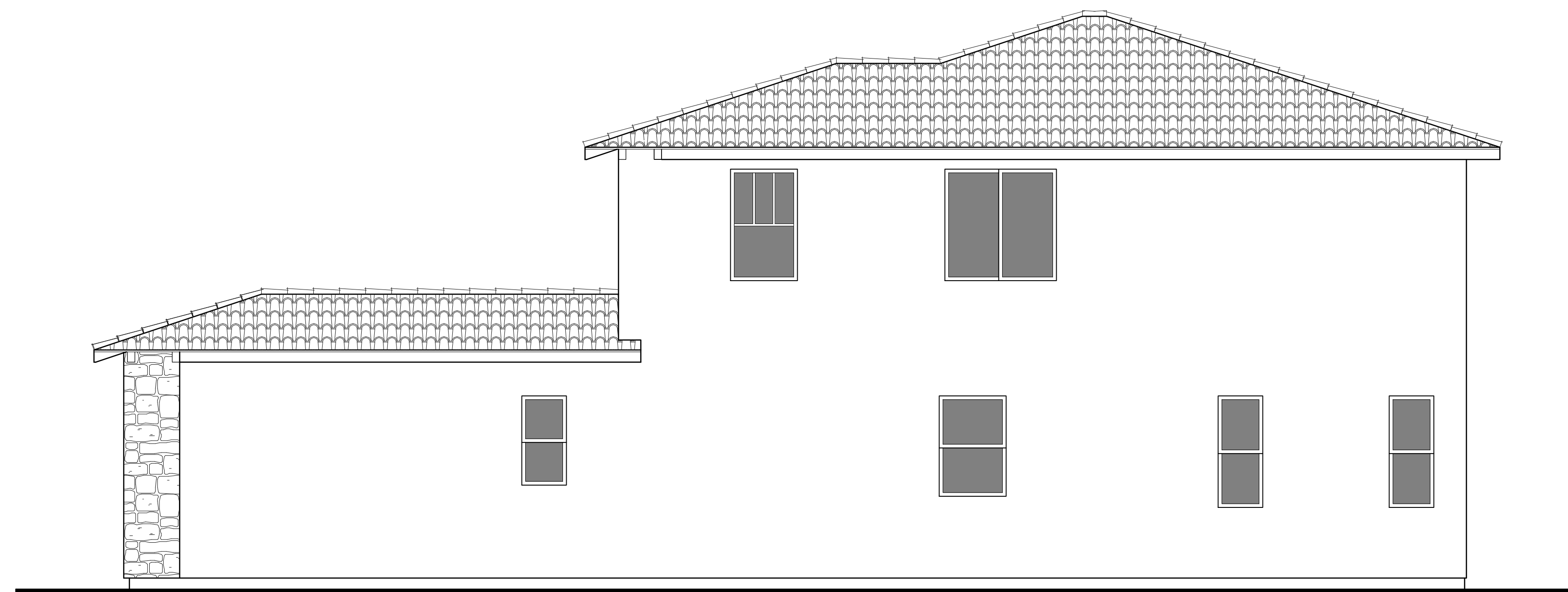

RIGHT

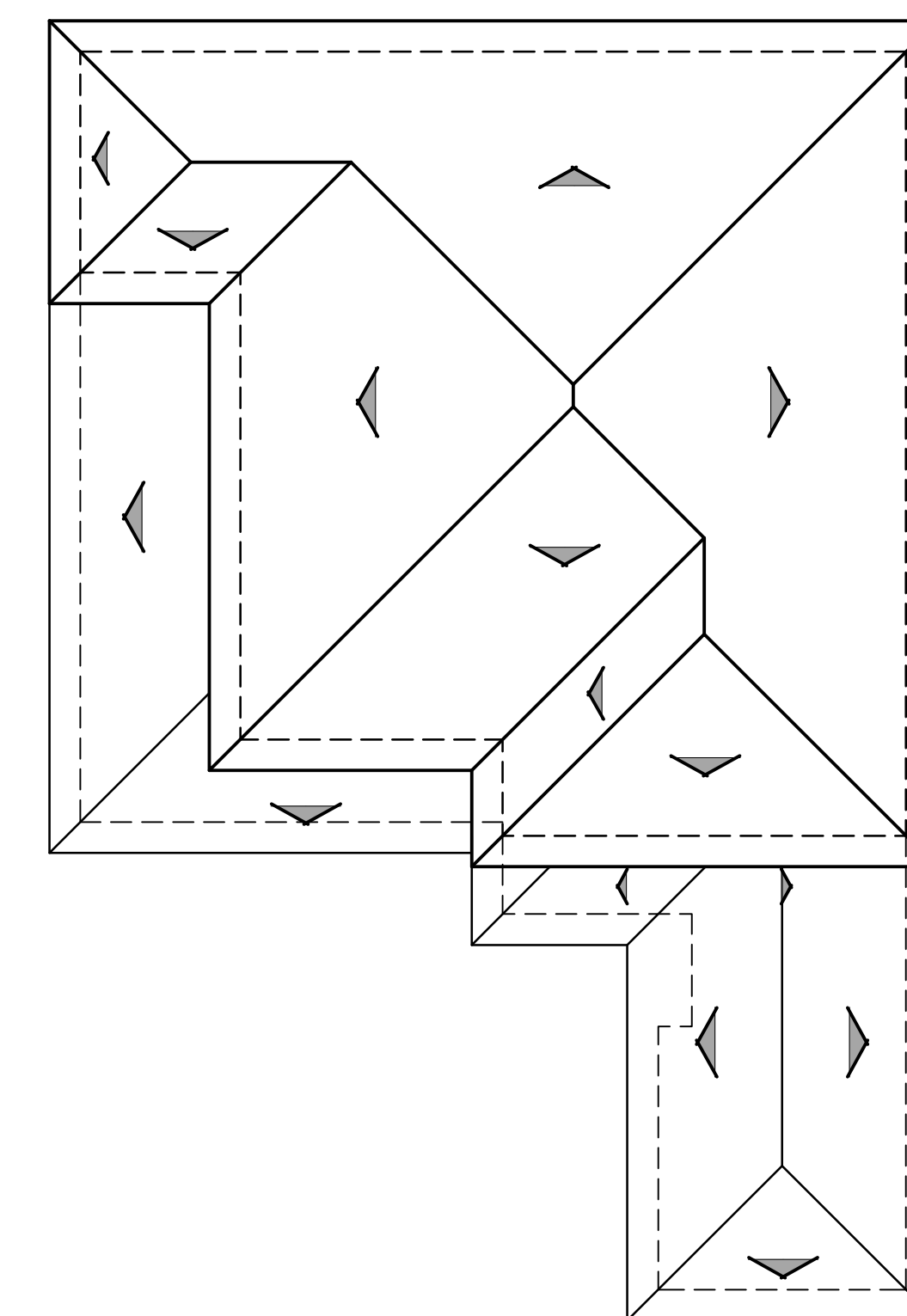

ROOF PLAN

C

PITCH: 4:12 U.N.O  
RAKE: 6"  
EAVE: 18"  
ROOF MATERIAL: CONCRETE 'S' TILE